



**AION** *Plus*

---

# Owner's Manual



# Foreword



Dear users,

Thank you for choosing an AION Y Plus - We value your trust in us.

We hope to bring you more driving fun with the best product and services.

Please read this manual thoroughly before driving to familiarize yourself with the functions and precautions of the vehicle.

When you are to resell this vehicle, please hand over this manual together with the vehicle to the new owner.

If you have any suggestions or comments to this manual, please call the GAC AION's customer service hotline.

Wish you a happy journey!

GAC Aion New Energy Automobile Co., Ltd.

April 2024

**GAC Aion New Energy Automobile Co., Ltd. All Rights Reserved!**

**No information contained in this manual is allowed to be reprinted or duplicated without the written permission of GAC Aion New Energy Automobile Co., Ltd.**

**All Rights Reserved!**

**Note: The model and illustration on the cover are for reference only. The actual vehicle shall prevail.**



## Introduction to the Owner's Manual

- Notices to users ..... 1
- How to read this manual ..... 2

## Preparations before use

- Linking the vehicle ..... 3
  - AION APP ..... 3
  - Linking the vehicle ..... 3
  - Window control\* ..... 5
- Preparations before driving ..... 7
  - Remote setting ..... 7
  - Check before driving ..... 7

## Unlocking of vehicle

- Key ..... 8
  - Smart key ..... 8
- Unlocking from outside ..... 10
  - Locating of vehicle ..... 10
  - Unlocking vehicle from outside ..... 10

## Trunk loading

- Opening of liftgate ..... 11
  - Opening of liftgate ..... 11
- Closing of liftgate ..... 14
  - Closing of liftgate ..... 14

## Entering the vehicle

- Opening of doors ..... 15
  - Opening doors from outside ..... 15
- Interior lighting ..... 16
  - Interior lighting ..... 16

## Riding

- Seat belt ..... 18
  - Introduction to seat belt ..... 18
  - Correct sitting posture ..... 19
  - Correct use of seat belts ..... 20
  - Seat belt use during pregnancy ..... 21
  - Seat belt reminder ..... 22

## Airbag ..... 23

- Introduction to airbag ..... 23
- SRS warning lamp ..... 25
- Airbag deployment ..... 26

## Child safety ..... 28

- Safety guidelines for child passengers ..... 28
- Child safety lock ..... 29
- ISOFIX child restraint system ..... 30
- LATCH child restraint system ..... 30
- Applicability of child seats ..... 31

## Sitting in front/rear seats ..... 34

- Switch-on/off of vehicle power supply ..... 34



- Seat adjustment ..... 35
- Adjustment of exterior rearview mirror ..... 37
- Adjustment of interior rearview mirror ..... 37
- Window control ..... 38
- Sunroof control ..... 39
- Steering wheel control ..... 41
- Steering wheel adjustment ..... 42
- Locking doors from inside ..... 43
- Ride comfort ..... 44**
- Wireless charging of mobile phone\* ..... 44
- A/C control ..... 45
- Seat ventilation\* ..... 48
- Storage space ..... 49
- Safety grip ..... 51
- Sun visor ..... 51
- Vanity mirror and vanity mirror lamp ..... 52
- 12V power outlet ..... 52
- USB port ..... 53
- Multimedia ..... 54**
- Multimedia control panel ..... 54
- Basic operations ..... 54
- Bluetooth connection ..... 57
- Voice assistant\* ..... 58
- Connection with mobile phone\* ..... 59
- Precautions for multimedia use ..... 60

## Driving

- Instruments ..... 62**
- Indicator lamps on instrument ..... 62
- Warning lamps on instrument ..... 65
- Instrument view ..... 67
- Information display ..... 68
- Tire Pressure Monitoring System (TPMS) ..... 70
- Pulling out ..... 72**
- Vehicle start ..... 72
- Switching of driving modes ..... 72
- Shifting gears ..... 74
- Speed control ..... 75**
- Pedals ..... 75
- Brake assist control systems ..... 76
- Acoustic Vehicle Alerting System (AVAS) ..... 78
- AUTO HOLD ..... 79
- Light control ..... 80**
- Light control ..... 80
- Intelligent High Beam Control (IHBC)\* ..... 82
- Wiper control ..... 84**
- Wiper control ..... 84
- Intelligent driving ..... 87**
- Forward Collision Warning (FCW)\* ..... 87



Autonomous Emergency Braking (AEB)* ..... 88	<b>Unlocking from inside..... 119</b>
Cruise Control System (CCS)* ..... 90	Unlocking doors from inside ..... 119
Adaptive Cruise Control (ACC)* ..... 91	Opening doors from inside ..... 119
Integrated Cruise Assist (ICA)* ..... 98	<b>After getting off..... 120</b>
Lane Departure Warning (LDW)* ..... 102	Safety notes before leaving ..... 120
Lane Keeping Assist (LKA)* ..... 105	
<b>Driving in special weather ..... 107</b>	<b>Vehicle locking</b>
Driving in fog ..... 107	<b>Locking from outside ..... 121</b>
Driving in rain ..... 107	Locking vehicle from outside ..... 121
Driving in hot seasons ..... 108	Folding of exterior rearview mirror 121
Driving in cold seasons ..... 109	<b>Anti-theft alarm system ..... 123</b>
	Body anti-theft ..... 123
<b>Parking</b>	<b>Leaving</b>
<b>Parking assist ..... 111</b>	<b>Charging..... 124</b>
Tilting down of exterior rearview mirror when reversing* ..... 111	Charging instructions ..... 124
Reversing Parking Aid (RPA) ..... 111	AC charging ..... 126
Surround View Monitor (SVM) ..... 112	DC charging ..... 129
<b>Getting off</b>	<b>Maintenance and cleaning</b>
<b>Preparations before getting off..... 115</b>	<b>Vehicle cleaning ..... 131</b>
Electric Park Brake (EPB) ..... 115	External cleaning ..... 131
Closing all windows ..... 117	Internal cleaning ..... 133
Closing sunroof ..... 118	<b>Vehicle maintenance ..... 135</b>
Follow Me Home ..... 118	External maintenance ..... 135
	Internal maintenance ..... 136
	Tire maintenance ..... 136



Corrosion protection measures ....	140	Jump start .....	166
Long-term storage of vehicle .....	141	Emergency start of vehicle .....	167
<b>Adding oils and fluids .....</b>	<b>142</b>	Emergency power-off of vehicle ..	168
Opening and closing hood.....	142	<b>Roadside assistance .....</b>	<b>169</b>
Adding windshield washer fluid ...	143	Freeing stuck vehicle .....	169
Checking coolant.....	144	Vehicle towing .....	169
Checking brake fluid.....	145	<b>Road accident rescue .....</b>	<b>172</b>
<b>A/C maintenance .....</b>	<b>146</b>	Rescue in case of driving through	
A/C filter.....	146	deep water .....	172
<b>Fuse replacement .....</b>	<b>147</b>	Rescue in case of battery	
Checking and replacing fuse .....	147	leakage .....	172
<b>Battery maintenance .....</b>	<b>149</b>	Rescue in case of vehicle fire .....	173
Low voltage battery maintenance.	149	<b>Technical information</b>	
Maintenance of traction battery ...	150	<b>Vehicle information .....</b>	<b>174</b>
<b>Emergency treatment</b>		Vehicle identification number	
<b>Emergency power supply.....</b>	<b>153</b>	(VIN) .....	174
Discharging instructions* .....	153	Vehicle nameplate and sticker .....	175
Discharging* .....	154	<b>Technical parameters .....</b>	<b>177</b>
<b>Emergency treatment by owner ..</b>	<b>157</b>	Technical parameters of vehicle ..	177
Emergency unlocking/locking .....	157	Technical parameters of motor ....	178
Window initialization .....	159	Technical parameters of traction	
Sunroof initialization .....	160	battery .....	179
Turning on hazard warning lamps	160	Wheel and tire parameters .....	180
Wearing reflective vest .....	161	Technical parameters of brake	
Setting up warning triangle .....	161	system .....	181
Emergency toolkit .....	162	Type and filled amount of vehicle	
Tire replacement .....	162	fluids .....	182



## Notices to users

### Configurations and options

This manual covers all the standard and optional configurations currently available for this product series. Therefore, some of the configurations and features described herein are not available on your vehicle. For specific configuration information of your vehicle, please refer to related sales materials or consult GAC AION sales store when buying a vehicle.

### Accessories, parts and modifications

Please use the genuine accessories and parts of GAC AION for replacement.

If accessories and parts not genuine to GAC AION are used for modification of the vehicle, we will refuse to provide warranty and bear any responsibilities and obligations arising therefrom. In addition, vehicle damage and performance degradation caused by the use of accessories and parts not genuine to GAC AION are not covered by the warranty.

Illegal modifications to the vehicle are prohibited.

### Scrapping of vehicle

Airbags contain explosive chemicals, and if they are not properly handled before vehicle scrapping, fire or other accident may occur. Always contact the GAC AION sales store or other qualified third party for dismantling and scrapping of the vehicle

### Event data recorder (EDR)

This vehicle is equipped with an EDR, which mainly records vehicle data at the time of collision for assistance in accident analysis. But, the data may not be recorded sometimes, depending on the severity and type of collision.

The data specially recorded by the EDR of this vehicle include:

- ◇ The status of driver depressing the brake pedal (if applicable).
- ◇ The vehicle speed.
- ◇ The longitudinal acceleration.
- ◇ The vehicle identification number.

These data allows us to better understand the situation of collision and injury or damage caused therefrom.

#### NOTE

- ◆ The EDR will record data only when a collision of certain degree occurs to the vehicle, that is to say, the EDR will not record data during normal driving.

#### EDR data disclosure

- ◇ We will not disclose the data recorded in the EDR to third parties except:
  - when a consent is obtained from the owner or lessee.
  - when an official request for disclosure is issued from the police, courts or other government agencies.
- ◇ However, we may apply the EDR data to the research and development of vehicle safety performance when necessary.

#### How to obtain EDR data reading tool

- ◇ Special technical equipment is required to read EDR data. For more information, please contact the GAC AION sales store.

#### Time-based effectiveness of the Manual

Due to continuous improvement and upgrade of vehicle, this manual may be updated irregularly without notice.

The screenshots of center console display, instrument and app interface contained in this manual are only applicable to the current version, and the display or process may change due to software update in the future. The latest interface shall prevail.







## How to read this manual

### Fast lookup

This manual is divided into several chapters in a logical way, and in order to help you find the desired information quickly, a navigation column is provided on the right margin of the odd pages.

And, the "Table of Contents" which is edited in the sequence of chapters and the alphabetical index at the end of this Manual can also help you quickly find the desired information.

### Symbols in the Manual

Symbol	Meaning
*	It is only applicable to some models or to some optional parts/features of some models.
	DANGER: Text with this symbol contains information about a high risk which, if ignored, will cause serious injury or even death.
	WARNING: Text with this symbol contains information about a medium risk which, if ignored, is likely to cause serious injury or even death.
	CAUTION: Text with this symbol contains information about a low risk which, if ignored, is possible to cause vehicle damage.
	NOTE: Text with this symbol contains additional useful information.
	Environment: Text with this symbol contains information on environmental protection.

### Illustrations in the Manual

The illustrations in this manual are for reference only. The actual vehicle shall prevail.

Unless otherwise specified, the directions of the vehicle (front, rear, left and right) referred to in this manual are based on the traveling direction of the vehicle.



## AION APP

The AION APP is an official platform that provides vehicle owners with professional vehicle use skills and knowledge as well as convenient remote vehicle control services.

With the AION APP, you can enjoy convenient functions such as vehicle status check, vehicle settings, and vehicle sharing, which will enhance your vehicle use experience.

You can search for "AION" in the app stores to download and install it onto your mobile phone.

### NOTE

- ◆ The AION APP interfaces contained in this manual are only applicable to the current version, and the display or process may change due to software update in the future.
- ◆ The specific functions of the AION APP are dependent on the actual configurations of your vehicle. For this reason, some functions may not be applicable to your vehicle.

## Linking the vehicle

The steps to activate your AION APP account and link the vehicle to your account are as follows:

1. Download and install the AION APP.

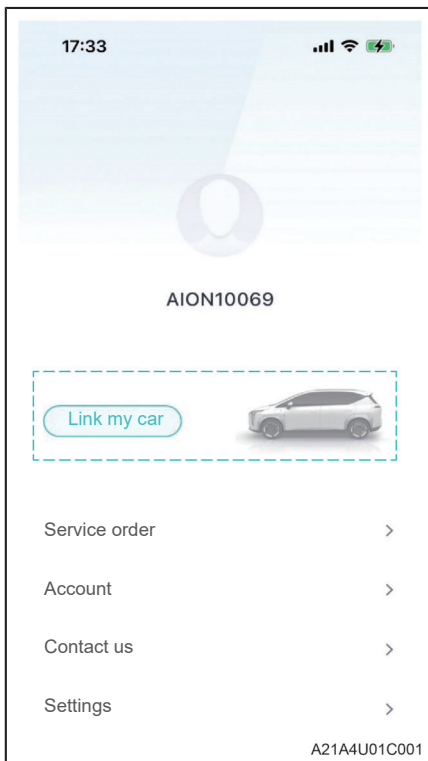

2. After registering for your AION APP account, touch "Link my car" to enter the owner authentication interface.



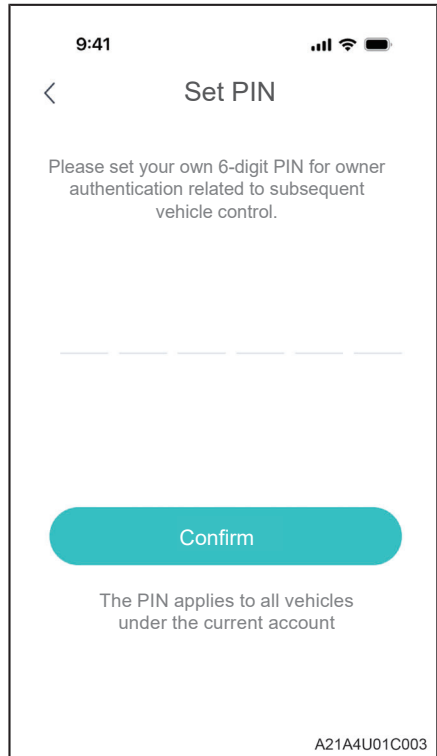
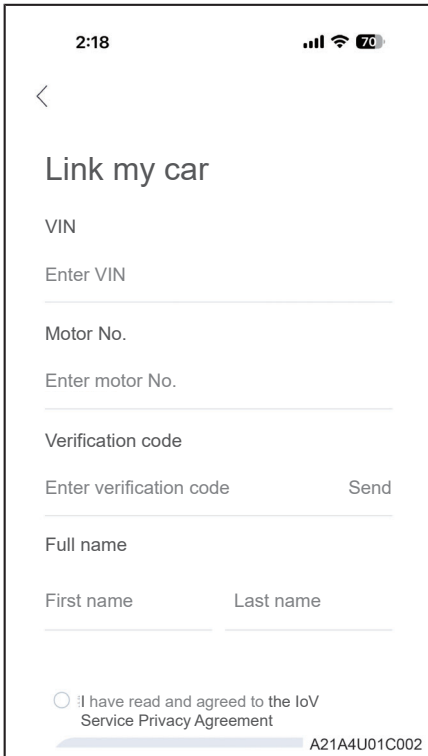

3. On the vehicle owner authentication interface, enter the VIN, motor number and other relevant information. After entering all the authentication information and agreeing to the privacy agreement, touch “Submit” for authentication.

4. After the owner authentication is completed, a PIN needs to be set to provide owner authentication for subsequent control of the vehicle. (If the current AION APP account has been linked to the vehicle, this step will be skipped)

### NOTE

- ◆ After the PIN is successfully set, it will be applicable to all vehicles linked to the current account. The vehicle owners do not need to set a PIN again when using their current account in the future.
- ◆ After the vehicle is successfully linked to the account, the AION APP will display different vehicle control items based on the model and its configurations.



## Vehicle control\*

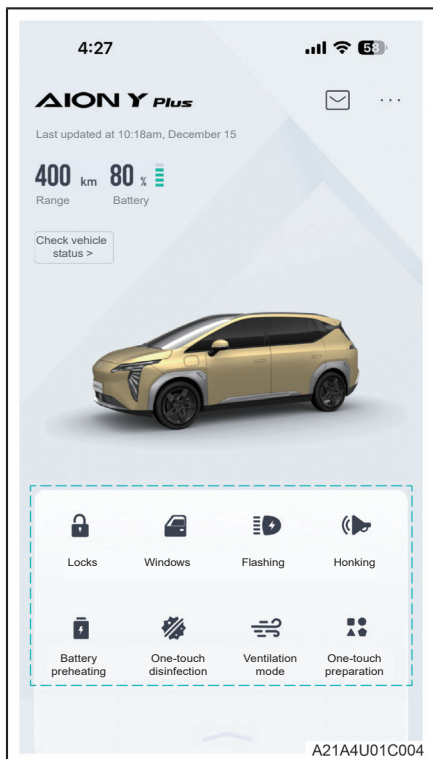

1. After the vehicle is successfully linked to the account, the vehicle can be remotely controlled on the vehicle control interface.

### NOTE

- ◆ Due to differences in model configurations, the final functions displayed by the vehicle control module are subject to the actual vehicle.

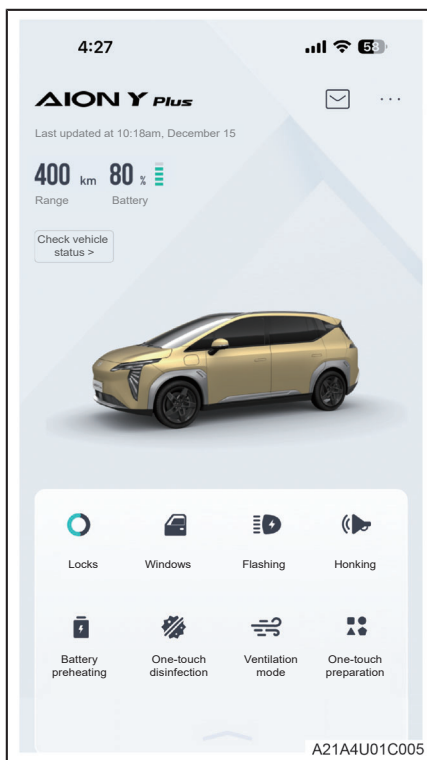

2. Touch the corresponding control button according to actual needs and then set your options (such as unlocking/locking the vehicle, adjusting the A/C temperature, etc.) by following the pop-up prompts on the page.

1

Preparations before use



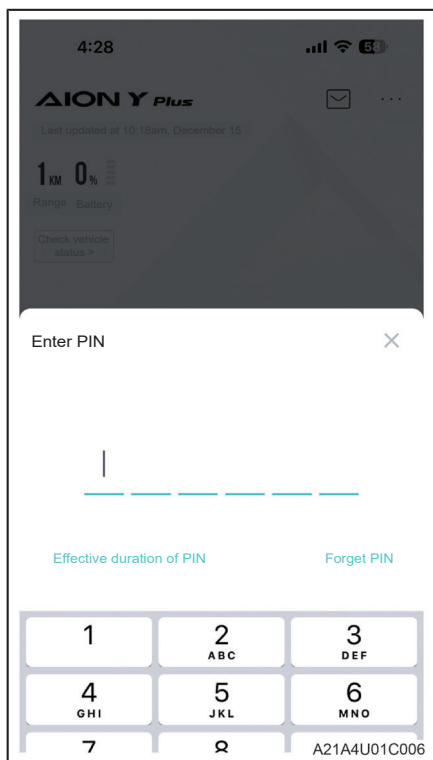

3. After the setting is completed, the PIN input interface will pop up. Enter the PIN, and the vehicle will perform the vehicle control operations you desire.



## Remote setting

After the vehicle is linked to the account, you can remotely set some vehicle functions through the AION APP before driving the vehicle. (if available)

Open the AION APP and enter the remote vehicle control interface, where you can remotely turn on the A/C, unlock/lock the vehicle, open the windows, etc. (if available)

### NOTE

- ◆ AION APP will be continuously optimized and updated. In order to have a better vehicle use experience, please update your AION APP to the latest version.

## Pre-drive check

Before driving, it is recommended to check the following:

- ◇ Tires
- ◇ Lamps
- ◇ Rearview mirrors
- ◇ Obstacles around the vehicle
- ◇ Fluid leakage at the bottom of vehicle
- ◇ Activated alarm or alert



## Smart key

The smart key is a physical key, which can realize common functions including locking/unlocking and vehicle startup.

### Introduction to buttons on smart key



- ① Locking button
- ② Remote power-on button
- ③ Liftgate opening button
- ④ Charger unlocking button
- ⑤ Unlocking button

### **i** CAUTION

- ◆ Never expose the smart key to direct sunlight, high temperature or high humidity for a long time.
- ◆ Prevent the smart key from dropping from height.
- ◆ Neither wet the smart key, nor wash it in the ultrasonic cleaning machine.
- ◆ Do not disassemble the smart key without authorization.
- ◆ To avoid scratch, do not put the smart key and sharp objects together.
- ◆ When taking a plane with a smart key, never press any button on it, otherwise, it will cause interference to the flying of plane.

### **i** CAUTION (Cont'd)

- ◆ Do not place the smart key near an object that can produce a magnetic field, such as TV set, AV unit, induction cooker or electronic medical device.
- ◆ If the smart key is lost, the vehicle will be at risk of theft. In this case, immediately go to the GAC AION sales store for treatment.

### **i** NOTE

- ◆ The smart key will not work after the vehicle enters the driving ready status.
- ◆ If the smart key malfunctions, it is recommended to press any button on it 3 times quickly in the vicinity of the vehicle to try to restore the smart key function.. If the smart key function cannot be restored, please contact the GAC AION sales store for inspection.
- ◆ Some functions of the intelligent may become unstable or fail under the following situations:
  - when the battery of smart key runs out.
  - when the smart key is operated in or near TV tower, charging station, power plant, airport and other places involving radio waves.
  - when the user carries the portable radio, mobile phone or other wireless communication devices.
  - when the smart key is in contact with metal objects or covered by other foreign bodies.
  - when there are other smart keys in use nearby.



**i NOTE (Cont'd)**

- ◆ As time goes, the battery of smart key may run out if any one of the following situations occurs. If this occurs, please replace the battery:
  - The remote control function of smart key fails.
  - The effective operation range of the smart key becomes smaller.
  - The indicator lamp on the smart key is off.
- ◆ The battery of smart key will run out if it is not used for a long time, and if this occurs, please get the battery replaced in the GAC AION sales store.



## Locating of vehicle

If you forget where your vehicle is parked, you can determine the approximate location of the vehicle through the AION APP. When you arrive near the vehicle, you can control the vehicle to flash lights and honk through the AION APP, or use the vehicle finding function of the smart key to do so to quickly find the vehicle.

### Locating vehicle on AION APP

You can check the parking location of the vehicle on the AION APP.

### Finding vehicle with smart key

After you are in the vicinity of vehicle, press the locking button  on the smart key 2 times quickly, and after this, the vehicle will give audible and visible alarms to remind you of the location of the vehicle.

## Unlocking vehicle from outside

### Unlocking by smart key button

With the vehicle locked, press the unlocking button  within the effective range of the smart key to unlock the vehicle.

### Intelligent active unlocking

When the intelligent active unlocking function is switched on in the center console display and you walk to the locked vehicle with smart key in hand, the vehicle will be automatically unlocked.

### Unlocking on AION APP\*

After the vehicle is linked to your AION APP account, you can unlock the vehicle on the vehicle control interface.

### NOTE

- ◆ The horn alarm for vehicle locking/unlocking can be switched on/off in the center console display.
- ◆ If no operation is made within a certain period after the vehicle is unlocked, the door will lock automatically.
- ◆ Remote vehicle control is susceptible to the network environment and may not work sometimes. Please do not use the remote vehicle control function to have the smart key locked inside the vehicle. (if available)



## Opening of liftgate

### Opening methods of liftgate

- ◇ Opening liftgate by smart key
  - With the smart key within the effective range, press and hold the liftgate opening button  to open the liftgate.
- ◇ Opening liftgate via sensing
  - After turning on the liftgate hands-free access function through the center control display, bring the smart key into the liftgate sensing area with all doors closed, and the liftgate will automatically open after a short period of time.

### NOTE

- ◆ The liftgate hands-free access function can be set to OFF, ONLY ON, or CHIME ON through the center control display.

- ◇ Opening liftgate by micro switch

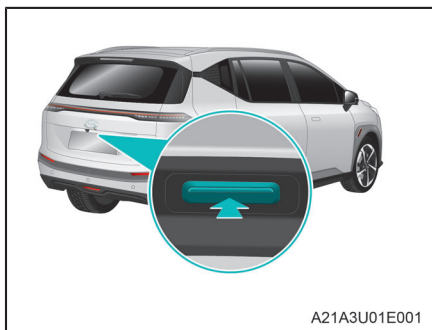

- When you press the liftgate micro switch with smart key in hand or after the vehicle is unlocked, the liftgate will automatically open.

### NOTE

- ◆ If the vehicle is not equipped with a power liftgate, the above methods can only unlock the liftgate. After unlocked, the liftgate still needs to be lifted manually.
- ◆ For some models, the liftgate can be opened through the center console display.
- ◆ For some models, the liftgate can be opened through the voice command.

### Setting the memory positions of liftgate

The memory positions can be set when the liftgate is opened more than halfway. After the setting is successful, the liftgate can only be opened to the memory position when it is opened electrically again.

- ◇ Ways to set the memory positions of liftgate



- Method 1: Open the liftgate, stop it at the appropriate position, and press and hold the liftgate closing button.
- Method 2: Open the liftgate, stop it at the appropriate position, and touch "Memorize Current Position" on the center control display.



- ◇ The buzzer sounds 2 times intermittently, indicating that the memory position is set successfully. If the buzzer sounds 4 times intermittently, it indicates that you failed to set the memory position.
- ◇ Ways to cancel the memory positions of liftgate
  - Method 1: After opening the liftgate to the memory position, push the liftgate above the memory position. The buzzer will sound, indicating that the memory position has been canceled.
  - Method 2: After opening the liftgate, touch "Clear Memory Position" on the center control display.

## DANGER

- ◆ Check that the liftgate is properly closed before driving. Otherwise, the liftgate may open accidentally and knock into the objects nearby, or the objects in the trunk may be thrown out, causing an accident thereafter.
- ◆ Prevent the children from playing in the trunk. Otherwise, they may be locked in the trunk by accident and suffer heatstroke, suffocation or other injuries thereafter.
- ◆ Prevent the children from operating the liftgate. Otherwise, the liftgate may be opened unexpectedly, or the children may be pinched by the closing liftgate.
- ◆ Do not take a ride in the trunk, otherwise serious injury or even death may be caused in the event of emergency braking or collision.

## WARNING

- ◆ Before opening or closing the liftgate, please thoroughly check the surrounding area for the sake of safety.

## WARNING (Cont'd)

- ◆ Remove all loads such as snow and ice on the liftgate before opening the liftgate. Otherwise, your body may be injured by the suddenly opened liftgate.
- ◆ Before accessing to the trunk, check that the liftgate is fully opened and secured. Otherwise, your body may be injured by the suddenly closed liftgate.
- ◆ Do not install any accessories on the liftgate. Otherwise, they will exert extra weight on the liftgate, causing unexpected closing of liftgate after opening and thereafter personal injury.
- ◆ Place loads evenly in the trunk and as near as possible to the rear seat back.
- ◆ Secure all loads in the trunk.
- ◆ Never load the trunk in such a way that the allowed axle load is exceeded.
- ◆ Never place fragile, flammable and explosive articles in the trunk.
- ◆ Ensure that container of fluids placed in the trunk will not leak.
- ◆ Be careful not to get your fingers or other body parts pinched when closing the liftgate.

## CAUTION

- ◆ For models equipped with a power liftgate, if the liftgate cannot be opened or closed electrically, please operate it manually slowly and do not use excessive force, otherwise the liftgate may malfunction or be damaged.
- ◆ Prevent the liftgate from scratching loads in the trunk when closing the liftgate, otherwise, the liftgate or concerning load may be damaged.



### CAUTION (Cont'd)

- ◆ Please avoid rubbing hard objects against the heating element on the rear windshield, otherwise the heating element may be damaged. (if available)
- ◆ Fill the trunk in a reasonable way, and if it is overfilled, do not close the liftgate forcibly, otherwise, the liftgate or loads in it may be damaged.

### NOTE

- ◆ The trunk lamp will come on for illumination when the liftgate is opened. If the liftgate is closed, the trunk lamp will go out automatically.
- ◆ If the liftgate is not completely closed, the trunk lamp may stay on.
- ◆ Disconnecting the negative terminal of the battery while the power liftgate is not completely closed will cause the liftgate to lose its memory position and disable its electric opening/closing function. After manually closing the liftgate completely, the electric opening/closing function will return to normal.

### NOT (Cont'd)E

- ◆ The liftgates of some models have an anti-pinch function:
  - During the electric closing of the liftgate, if the anti-pinch strips on both sides are squeezed by external forces, the liftgate will stop closing and then open electrically to the original position.
  - During the electric closing of the liftgate, if an obstacle prevents the liftgate from closing, the liftgate will stop closing and then open electrically to the original position.
  - During the electric opening of the liftgate, if an obstacle prevents the liftgate from opening, the liftgate will stop opening and then reverse electrically for a certain distance before stopping.
  - After the anti-pinch function is triggered three times in a row, the anti-pinch protection function is activated, and the power liftgate function becomes invalid. In this case, the power liftgate must be closed manually before the electric opening/closing function can be restored.



## Closing of liftgate

### Electric closing of liftgate\*

- ◇ Closing liftgate by smart key
  - When the liftgate is open, with the smart key within the effective range, press and hold the liftgate opening button  on the smart key to automatically close the liftgate.
- ◇ Closing liftgate by liftgate button



- When the liftgate is open, press the button on the liftgate to automatically close the liftgate.

### NOTE

- ◆ For some models, the liftgate can be closed through the center console display.
- ◆ For some models, the liftgate can be closed through the voice command.

### Closing liftgate manually

The manual closing method of the liftgate is as follows:



1. Pull the liftgate closing handle to lower the liftgate appropriately.
2. Press the liftgate from the outside until the liftgate is locked securely.

## Opening doors from outside

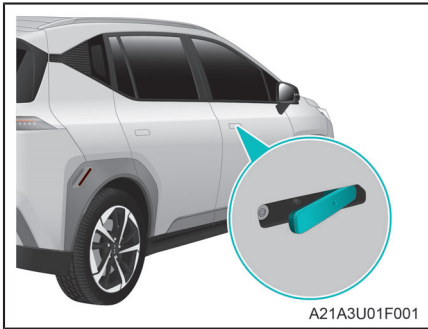

Unlock the vehicle, and after the hidden door handle extends automatically, pull the handle to open the door.

### **WARNING**

- ◆ Prevent hand pinching by door handle when locking the vehicle.

### **CAUTION**

- ◆ Do not press the extended door handle forcibly, otherwise, the door handle will be damaged.
- ◆ Stow the hidden door handle before washing the vehicle, so as to avoid water entry into the inside of door handle during washing and thereafter vehicle damage.



## Interior lighting

### Intelligent ambient light (IAL)\*

If the IAL function is switched on on the center console display, the interior ambient light will come on after the power switch is set to ON, providing for driver a slightly bright and comfortable driving environment, alleviating driving fatigue and enhancing driving experience.

On the center console display, you can also set the brightness of the ambient light, turn on and off the music following mode (if available), turn on or off the drive mode following mode, and select the color of the ambient light.

#### NOTE

- ◆ The ambient light is automatically turned off when the rest mode is activated, but can be turned back on on the center console display. The ambient light is turned on automatically after the vehicle exits the rest mode. (if available)

- ◇ Music following mode of ambient light\*
  - After the music following mode is turned on, the ambient light will automatically change color and brightness according to the rhythm of the music.

#### NOTE

- ◆ The music following mode is only supported by the USB music, Bluetooth music, CarLife music (if available), CarPlay music (if available), and online music (excluding online radio music). Other audio sources do not support the music following mode.

- ◇ Drive mode following mode of ambient light
  - When the drive mode following mode is activated, the ambient light will automatically change colors according to the drive modes of the vehicle.

Driving mode	Ambient light color
ECO	Green
NORMAL	White
SPORT	Red
I-PEDAL	Ice blue

### Reading lamp

#### Automatic on/off of reading lamp

- ◇ Touch the button on the center console display to enter the quick control interface, and set the reading lamp to DOOR position, so the reading lamp will be turned on/off automatically according to the status of door and vehicle power supply.

#### Manual on/off of reading lamp

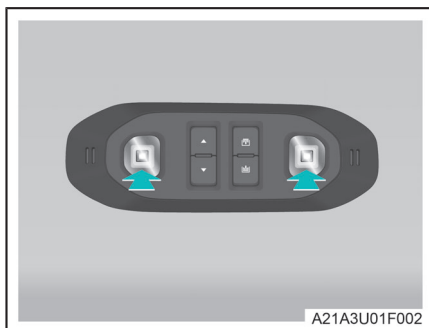

- ◇ Press a front reading lamp to turn on/off the front reading lamp of concerning side.





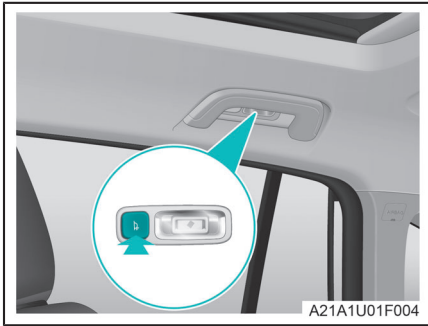

- ◇ When you press the rear reading lamp switch on both sides, the rear reading lamp of concerning side will be turned on/off.



## Introduction to seat belt

Seat belt is a main safety protection device, which can effectively reduce personal injury in an accident when being used together with the airbag. Therefore, be sure to fasten the seat belt before driving.

### WARNING

- ◆ Each seat belt is for one person only. Do not share a seat belt with other persons (including children).
- ◆ Passengers in rear seat are also required to fasten the seat belt properly; otherwise, they may be thrown out when an accident occurs, and then they will be injured seriously and even cause serious personal injury to other passengers and the driver.
- ◆ Put the child in a rear seat, and use a suitable child restraint system.
- ◆ Take the correct sitting posture, so as to ensure that the seat belt will play to its full for safety protection in case of emergency braking or accident.
- ◆ It is prohibited to use the corresponding seat until the seat belt fault has been repaired.
- ◆ Never install, remove, modify, disassemble or dispose of a seat belt without authorization.

### CAUTION

- ◆ Prevent the seat belt and its tongue from being pinched by the door, otherwise, the seat belt may be damaged.
- ◆ Check the seat belts regularly.
- ◆ If the seat belt assembly does not work properly, it is recommended to contact the GAC AION sales store for repair or replacement immediately.
- ◆ Always replace the seat belt system (including its bolts) if it is used during a serious collision accident, even though no obvious damage is found.



## Correct sitting posture

### Correct sitting posture of the driver



1. Adjust the seat position so that the pedal is easily accessible and the elbow is slightly bent when you hold the steering wheel.
2. Adjust the seat back so that you can operate the steering wheel when you sit up straight without leaning forward.
3. Adjust the headrest so that the center of the headrest is flush with the upper end of ears.
4. Fasten the seat belt correctly.

### Correct sitting posture of the passengers

1. Adjust the position of front passenger's seat to keep an appropriate distance from the instrument panel.
2. Adjust the front passenger's seat back so that your back is straight up and fits the seat back closely.
3. Adjust the headrest to ensure that the center of the headrest is flush with the upper end of the passenger's ears.
4. Fasten the seat belt correctly.

### WARNING

- ◆ During driving, maintain a correct sitting posture, and keep your back fitting the seat back closely, otherwise serious injury may occur in case of emergency braking or accident.
- ◆ The driver should keep a proper distance from the steering wheel.
- ◆ Do not place a back cushion on the seat.

### NOTE

- ◆ The driver's seat can be adjusted longitudinally by 240mm, and the standard longitudinal seat position is 40mm in front of the rearmost position; the seat back can be adjusted forward from the standard position by 20° and backward by 66°; the driver's seat can be adjusted vertically by 55mm, and the standard vertical seat position is 27.5mm above the lowest position.
- ◆ The front passenger's seat can be adjusted longitudinally by 240mm, and the standard longitudinal seat position is 40mm in front of the rearmost position; the seat back can be adjusted forward from the standard position by 20° and backward by 66°.



## Correct use of seat belts

### Fastening the seat belt correctly

1. Adjust the sitting posture correctly.

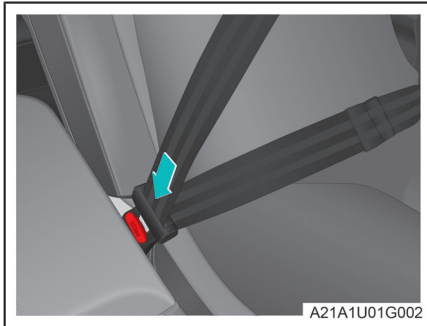

2. Gently pull out the seat belt, route it across the chest and hip, and insert the tongue into the buckle until you hear and feel the latch engage.
3. Pull the seat belt in the opposite direction, confirming that the seat belt is locked securely.
4. Adjust the position of the seat belt.
  - Always route the shoulder belt over your shoulder. The belt should be away from your neck, but not falling off your shoulder.
  - The lap belt should be worn low across the pelvis.

### Unfastening the seat belt

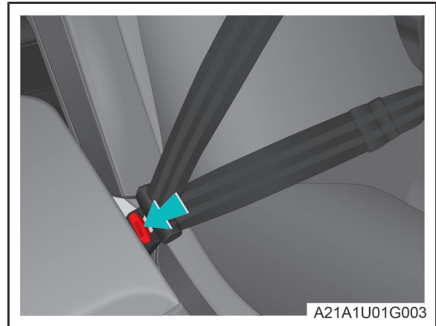

1. Hold the seat belt and press the red button next to the seat belt buckle, so the tongue will spring up automatically.
2. Slowly retract the seat belt back into the retractor.

#### DANGER

- ◆ Do not place the shoulder belt under the arm.
- ◆ The lap belt should be worn as low as possible across the pelvis, and if it is worn too high or is not properly tensioned, the occupant may suffer personal injury or even death due to body movement in the event of collision or other accident.

#### WARNING

- ◆ Never unfasten the seat belt when the vehicle is running or before the vehicle comes to a complete stop.
- ◆ After the tongue springs up, guide the seat belt back to retract slowly with hand, so as to prevent personal injury due to quick retraction of seat belt.

## WARNING (Cont'd)

- ◆ For patients and disabled persons, please follow the doctor's advice, and be sure to wear the seat belt.
- ◆ Do not place any item between the body and the seat belt.

## CAUTION

- ◆ If the seat belt cannot be retracted smoothly, check it for twist or deflection. If the seat belt assembly does not work properly, it is recommended to contact the GAC AION sales store for repair or replacement immediately.
- ◆ Buckles of rear seat belts are placed in grooves of rear seats. Rear seat occupants can take them out when necessary to wear seat belts. Buckles of seat belts should be put into the grooves after use.

## Seat belt use during pregnancy

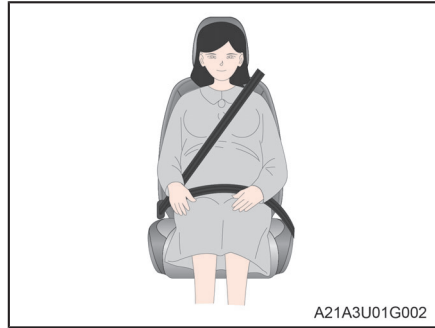

For pregnant women, wearing a seat belt correctly can effectively reduce the injuries suffered by her and her fetus in case of collision or sudden stop.

The shoulder belt should be worn across the shoulder, and the lap belt should be worn low across the pelvis and away from the abdominal area. The seat belt must be worn smoothly, without exerting stress to the lower body of pregnant women.

## DANGER



- ◆ The pregnant occupant should consult her physician to fasten the seat belt correctly.
- ◆ Be sure to wear the seat belt correctly, otherwise the pregnant woman and her fetus will be seriously injured or killed in case of emergency braking or collision.

## WARNING

- ◆ Do not place any item between the body and the seat belt.



## Seat belt reminder

If the driver or passenger does not fasten the seat belt after the vehicle is started, the indicator lamp  or  on the instrument will flash or stay on.

### NOTE

- ◆ If the driver or front passenger does not fasten the seat belt at a certain vehicle speed, the buzzer will sound, and a corresponding warning text message will be shown on the instrument.

## Introduction to airbag

In the event of a serious collision, the airbag will inflate and deploy quickly to reduce the risk of serious injury to the passenger inside the vehicle together with the seat belt.

### Layout of airbags

The supplemental restraint system (SRS) consists of driver's airbag (in the steering wheel trim cover), front passenger's airbag (in the instrument panel in front of the front passenger), side airbag (in the front seat) and side curtain airbag (in the left and right roofs), and all the arrangement positions of airbags are identified with the "AIRBAG" marking.

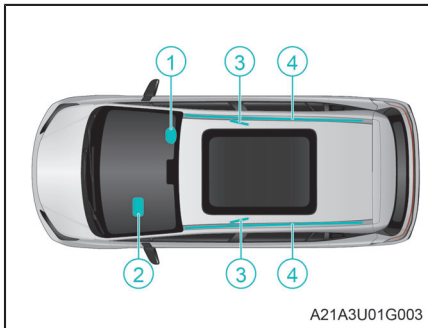

- ① Driver's airbag
- ② Front passenger's airbag
- ③ Front side airbag
- ④ Side curtain airbag

### DANGER

- ◆ The driver and all passengers in the vehicle must fasten the seat belt correctly.
- ◆ The airbag will produce a great impact force during deployment, and will cause serious personal injury or even death when the passenger is sat too close to the airbag.
- ◆ The infants and babies may be seriously injured or even killed by the deployed airbag if not properly protected. When the baby is too small to use the seat belt, it is required to apply an appropriate child restraint system for protection.
- ◆ Do not place, install or paste any objects on the instrument panel, steering wheel, or other places where the airbag is installed. Otherwise, those objects will be ejected when the driver's airbag or front passenger's airbag deploys, causing serious injury or even death.
- ◆ Never use seat accessories that will cover the front side airbag; otherwise, such accessories may hinder the deployment of front side airbag, causing system failure or unexpected deployment of front side airbag, and thereafter serious injury or even death of passengers.
- ◆ Never install or paste any object on windshield, door window, side pillar, roof, etc.
- ◆ Do not attach coat hanger or other hard objects to the roof or safety grip. Otherwise, they will be ejected when the side curtain airbag deploys, causing serious injury or even death of passengers.



 **DANGER (Cont'd)**

- ◆ Never install, remove, modify, disassemble or dispose of the SRS without authorization.
- ◆ Before scrapping the vehicle, it is recommended to contact the GAC AION sales store or other qualified third party for dismantling and scrapping of the airbag.

 **WARNING**

- ◆ Maintain a correct sitting posture and fasten the seat belt properly when the vehicle is traveling.
- ◆ Adjust the front seat to such a position that it is enough far away the instrument panel or steering wheel, and adjust the seat back straight up as much as possible.
- ◆ Never allow a child to take the front passenger's seat.
- ◆ Do not sit on the edge of the seat or lean on the instrument panel.
- ◆ Do not lean on the door and side pillar.
- ◆ Never place any object on the leg when the vehicle is traveling.
- ◆ Ask passengers not to kneel on the seat towards the door or stretch any body part out of the vehicle.
- ◆ Immediately after the airbag is deployed, do not touch any related parts for fear of scalding.
- ◆ If you feel breathless after the airbag is deployed, open the door or window for ventilation, and leave the vehicle provided the safety is ensured, and rinse away the residues on the body.
- ◆ The airbag is designed for deployment by one time only, and if it is deployed, always replace it with a new one.

 **CAUTION**

- ◆ Neither hit nor exert a great force to the area where the airbag component is located or the front door, otherwise it may cause failure or unexpected deployment of airbag.
- ◆ Check the SRS regularly. If any of the following conditions occur, it is recommended to contact the GAC AION sales store for inspection or replacement of SRS as soon as possible:
  - when any airbag is deployed.
  - when the front part of the vehicle, the door or the area around the door is damaged or deformed, or the vehicle incurs an accident that is not sufficient to deploy the airbag.
  - when the airbag is scratched, cracked or otherwise damaged.

 **NOTE**

- ◆ The driver is required to keep a distance of about 25cm from the driver's airbag. If the distance is less than 25cm after sitting, please adjust the seat position. Ensure that the driver's seat is such adjusted that the brake pedal, steering wheel and control switches are easily accessible to ensure effective control.
- ◆ When the vehicle is resold, keep the new owner informed of the arrangement and replacement record of airbags on the vehicle.





## SRS warning lamp

After the vehicle is started, the SRS warning lamp  will be on for several seconds, and then go out when no problem is found after self-test. If the warning lamp does not go out after self-test, or goes on again during driving, it indicates that the SRS is faulty, and in this case, please contact the GAC AION sales store for inspection or replacement.



## Airbag deployment

The deployment of airbag depends on the vehicle speed, collision angle, accident type, obstacle and other factors at the time of collision.

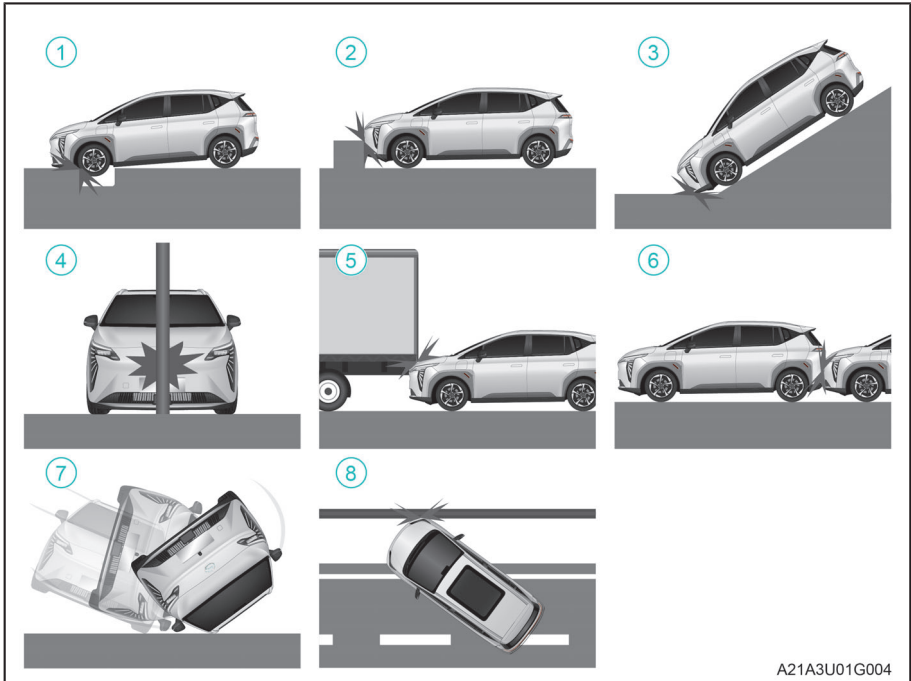

The airbag may deploy under the following situations:

- ① Nose-down to the ground when the vehicle crosses a deep groove.
- ② Hitting a roadside protrusion, curb, etc.
- ③ Nose-down to the ground when the vehicle runs down a steep slope.

The airbag may not deploy under the following situations:

- ④ A collision with concrete pillars, trees or other elongated objects.
- ⑤ A rear-end collision with lower end of a truck.
- ⑥ A rear-end collision by another vehicle.
- ⑦ A rollover.
- ⑧ A collision with a wall or another vehicle, other than frontal collision.

**i NOTE**

- ◆ When the airbag deploys:
  - The deployment (inflation) speed is very high, which may cause minor scratch, scalding or other injury.
  - It will produce large noise and a small amount of smoke.
  - The airbag and the area around it will be very hot.
  - The windshield may be broken.
  - The vehicle will automatically cut off the high-voltage power supply.
  - The hazard warning lamp will be turned on automatically.



## Safety guidelines for child passengers



Please follow the warning label on the sun visor: Do not install a child restraint system on the front passenger's seat.

### DANGER

- ◆ Do not place a rear-facing child seat on the seat with frontal airbag. Otherwise, the child may be seriously injured or even killed by the impact force produced by sudden inflation of front passenger's airbag when an accident occurs.
- ◆ Always install the child seat in strict accordance with the installation instructions provided by the manufacturer of the child restraint system. Otherwise, the child may be seriously injured or even killed in case of emergency braking, emergency steering or accidents.
- ◆ It is not recommended to hold the child for protection, because the child may bump into the windshield or be crushed in the event of an accident.
- ◆ Never leave the child alone in the vehicle, and ask the child not to use the smart key.

### DANGER (Cont'd)

- ◆ Do not allow the child to lean on the airbag deployment area such as door and side pillar even if he/she is well protected in the child seat. Otherwise, the child may be seriously injured or even killed by the impact force produced by airbag deployment.
- ◆ The installation of a child seat on a rear seat may affect the use of seat belt of adjacent seat.
- ◆ Prevent the child from playing with the seat belt. Otherwise, when the seat belt is entangled around the child's neck, suffocation, or other serious injury and even death may be caused. If this happens and the seat belt cannot be unbuckled, it is recommended to cut the seat belt with a pair of scissors.

### WARNING

- ◆ Please choose a child seat suitable for the age, height and weight of the child.
- ◆ Before driving, please apply the child safety lock and lock the window of concerning side, so as to prevent the child from opening the door or door window unexpectedly.
- ◆ To install the child seat on a rear seat, please adjust the front seat to such a position that the access of child and the use of child seat will not be affected.
- ◆ If the driver's seat position causes inconvenience to the use and installation of child seat, please install the child seat on the right rear seat.

## WARNING (Cont'd)

- ◆ Always use the child seat in strict accordance with the operation instructions provided by the manufacturer of the child restraint system.
- ◆ Please restrain the child on the seat properly even if the child restraint system is not used. Do not place a child seat in the vehicle without proper securing.

## CAUTION

- ◆ The child restraint system may incur hardly-detectable damage when the vehicle is heavily collided in an accident, and thus after a serious collision, please stop using the child restraint system.

## NOTE

- ◆ Always remember and abide by the precautions and regulations related to the child restraint system.
- ◆ Not all child seats are suitable for this vehicle. Therefore, please confirm the suitability of the child seat to be used or bought.
- ◆ The child seat has high restraint and inclusion effect, and thus it is recommended to apply the child seat from the time when the baby is born to make him/her be accustomed to the child seat, and intermittent use may stimulate his/her dislike to the child seat.

## Child safety lock

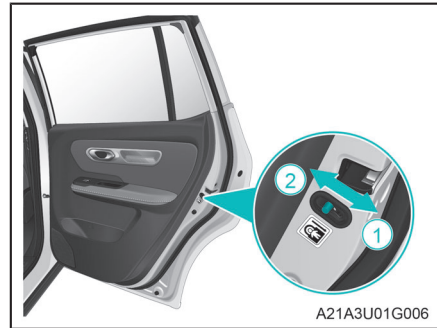

When a child takes a rear seat, please move the switch to locking position ① before closing the door. At this time, the door cannot be opened from inside, so as to prevent the child from opening the door unexpectedly.

To unlock the child safety lock, open the door from outside, and move the switch to unlocking position ② .



### ISOFIX child restraint system

ISOFIX interface is an anchorage interface for hard connection with the child seat which supports the ISOFIX system.

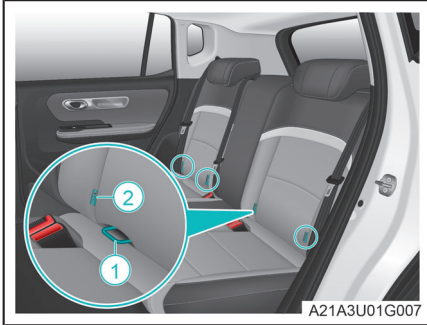

There are four ISOFIX anchorages ① provided between the rear seat back and the rear seat cushion for installation of child seat. Label ② is used to indicate the position of ISOFIX anchorage.

### LATCH child restraint system

LATCH interface is an anchorage interface for flexible connection with the child seat which supports the LATCH system.

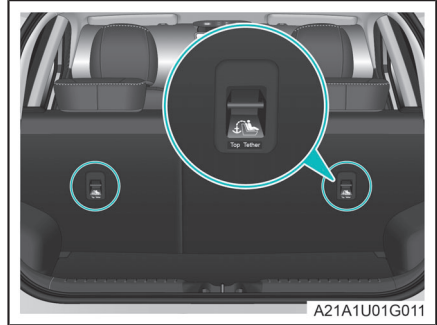

The LATCH anchorage is located on the back of rear outboard seat.



## Applicability of child seats

Please select an appropriate child seat and install it in the correct position according to the table below.

### Information about the applicability of different seating positions for child seats

Weight group	Seating position		
	Front passenger's seat	Rear outboard seat	Rear center seat
Group 0 (0~10kg)	X	U	X
Group 0+ (0~13kg)	X	U	X
Group I (9~18kg)	X	U/UF/L	X
Group II (15~25kg)	X	UF	X
Group III (22~36kg)	X	UF	X

The meanings of letters in the table are as follows:

U = Suitable for general category child restraint system approved for this weight group.

UF = Suitable for general category forward-facing child restraint system approved for this weight group.

X = Not suitable for child restraint system of this weight group

L = Suitable for the listed special child restraint systems, which may be for special vehicles, or of restricted or semi-general categories.

#### NOTE

- ◆ For some child safety seats, a size class is specified. Be sure to check the size class according to the manufacturer's instructions, packaging, and child safety seat label. For guidance on proper installation, please refer to the instructions of the child safety seat.



Information about the applicability of different ISOFIX positions for ISOFIX child seats

Weight group	Size class	Fixture module	Seating position		
			Front passenger's seat	Rear outboard seat	Rear center seat
Carry-cot	F	ISO/L1	X	X	X
	G	ISO/L2	X	X	X
Group 0 (0~10kg)	E	ISO/R1	X	IUF/IL	X
Group 0+ (0~13kg)	C	ISO/R3	X	IUF/IL	X
	D	ISO/R2	X	IUF/IL	X
	E	ISO/R1	X	IUF/IL	X
Group I (9~18kg)	A	ISO/F3	X	IUF/IL	X
	B	ISO/F2	X	IUF/IL	X
	B1	ISO/F2X	X	IUF/IL	X
	C	ISO/R3	X	IUF/IL	X
	D	ISO/R2	X	IUF/IL	X
Group II (15~25kg)	/	/	X	IUF	X
Group III (22~36kg)	/	/	X	IUF	X

The meanings of letters in the table are as follows:

IUF = Suitable for general category forward-facing ISOFIX child restraint system approved for this weight group.

IL = Suitable ISOFIX child restraint system recommended for this vehicle.

X = ISOFIX positions are not suitable for ISOFIX child restraint system of this weight group/size class.

**NOTE**

- ◆ For some child safety seats, a size class is specified. Be sure to check the size class according to the manufacturer's instructions, packaging, and child safety seat label. For guidance on proper installation, please refer to the instructions of the child safety seat.





**Size class and description of corresponding child seat**

Size class	Description of corresponding child seat
A	Full-height front-facing child seat for toddler
B	Height-reduced front-facing child seat for toddler
B1	Height-reduced front-facing child seat for toddler
C	Full-size rear-facing child seat for toddler
D	Size-reduced rear-facing child seat for toddler
E	Rear-facing child seat for infant
F	Left-facing child seat for infant (carry-cot)
G	Right-facing child seat for infant (carry-cot)





## Switch-on/off of vehicle power supply

### Switching on the vehicle power supply

After the vehicle is unlocked and either front door is opened, the center console display will go on, and the vehicle power supply will be switched on automatically.

### Switching on the vehicle power supply by remote control

To switch on the vehicle power supply by remote control, press the locking button  on the smart key within the effective range of the smart key, and then press and hold the power-on button  on the smart key quickly until the turn signal lamps flash, indicating that the vehicle power supply is switched on successfully by remote control.

### Entering driving ready status

When you close the doors, fasten the seat belt, depress the brake pedal, and move the column shifter to select the desired gear, the indicator lamp **READY** on the instrument will come on, indicating that the vehicle is ready for driving.

### Switching off the vehicle power supply

After driving, stop the vehicle and set the gear to "P". After the driver and front passenger get off the vehicle and lock it, the vehicle power supply will be switched off automatically.

The vehicle power supply can also be switched off through the drop-down menu of the center console display.

### Power holding

When the driver needs to leave the vehicle temporarily while requiring the on-board electrical consumers to remain operational (for example, keep the A/ C working when there is an elderly person or a child in the rear seat), please stop the vehicle in a safe place, set the gear to "P", and enable the power holding function through the drop-down menu of the center console display. Then after you get off the vehicle, the vehicle power supply will not be switched off, and on-board electrical consumers will keep working.

### NOTE

- ◆ If the front passenger's seat is still occupied by a person after the driver gets off the vehicle, the vehicle power supply will not be switched off automatically, and the on-board electrical consumers will keep working.
- ◆ If the battery SOC drops below 10% with the power holding function activated, the vehicle power supply will be switched off automatically for power saving.
- ◆ After the power holding function is activated, the anti-theft alarm and intelligent active locking/unlocking function are disabled, and the vehicle can be locked with the smart key.
- ◆ The vehicle power supply will be switched on automatically when the front door is opened, and if the driver's seat and front passenger's seat are not occupied, the vehicle power supply will be switched off automatically after a certain period of time for power saving.
- ◆ After driving, stop the vehicle and set the gear to "P". After the driver and front passenger get off the vehicle but do not lock it, the vehicle power supply will not be switched off automatically. But when the battery SOC is too low, the vehicle power supply will be switched off automatically.
- ◆ If you press and hold the remote power-on button  on the smart key with vehicle locked after the vehicle power supply is switched on by remote control, the vehicle power supply can be switched off by remote control.
- ◆ If no operation is performed on the vehicle after the vehicle power supply is switched on by remote control, the vehicle power supply will be switched off automatically after a certain period of time.



## Seat adjustment

### Headrest adjustment

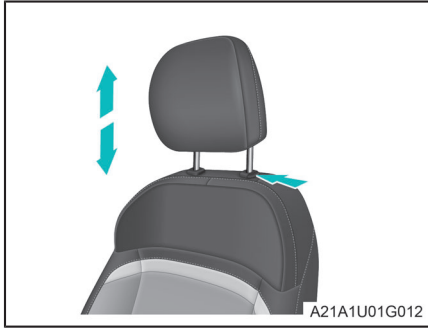

**Pull the headrest up to the appropriate position.**

Press the headrest button while pressing the headrest down in place, and then release the button.

### Power seat adjustment

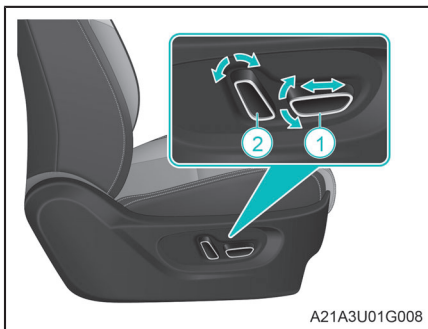

1. Push the seat position adjusting switch ① forward and backward to adjust the front and rear positions of the seat.
2. Turn the tip of the seat position adjusting switch ① up and down to adjust the seat height. (if available)
3. Turn the seat back reclining switch ② forward and backward to adjust the tilt angle of the seat back.

### Manual seat adjustment

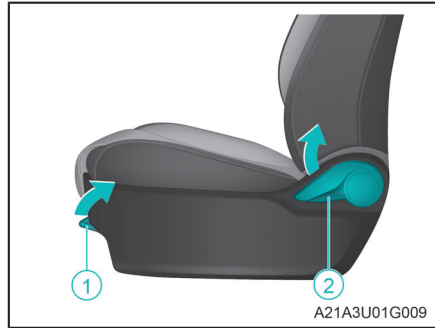

1. Pull up the middle of the seat position adjusting lever ①, slide the seat to the required position, and release the adjusting lever.
2. Pull up the seat back reclining handle ②, tilt the seat back forward or backward by the back pressure to adjust the seat back to the desired angle, and then release the handle.

### Rear seat folding

1. Adjust the rear seat headrest to the lowest position.

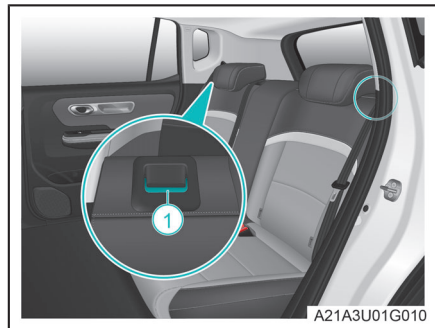

2. Pull the folding handles ① on the left and right of rear seat to unlock the rear seat.
3. Pull the rear seat back forward to make it come into contact with the seat cushion, and fold the rear seat back.



Push the rear seat back in contact with the seat cushion backward to the locking position to restore the rear seat back.

### DANGER

- ◆ It is forbidden to adjust the seat during driving. Otherwise, the seat may move unexpectedly, causing the driver to lose control of the vehicle.
- ◆ It is forbidden to tilt the seat back excessively. Otherwise, the lap belt may slip over the hip and directly strangle the abdomen, or the shoulder belt may touch the neck, thus increasing the risk of serious injury or even death in case of accident.
- ◆ During driving, never sit in a folded seat or in the trunk.

### WARNING

- ◆ Please take care not to hurt other passengers when adjusting the seat position.
- ◆ Make sure there is enough space for feet, for fear of pinch injury.
- ◆ Do not place hands under the seat or near moving parts, for fear of pinch injury.
- ◆ For manual adjustment of the tilt angle of the seat back, make sure that the body back gets close to the seat back to prevent unnecessary injury caused by fast folding of the seat back.
- ◆ After the seat is adjusted, try pushing the seat and seat back forward and backward to make sure that the seat and seat back are firmly locked.

### CAUTION

- ◆ When front seat backs are laid flat, it is forbidden to ride or place heavy objects on the seat backs. Otherwise, the seats may be damaged.
- ◆ Rear seat backs shall be folded and unfolded slowly to avoid damage or abnormal function of the rear seat belts.

### NOTE

- ◆ For some models, the driver's seat can be adjusted through the center console display.
- ◆ The power seat cannot be adjusted a period of time after the collision.
- ◆ Rear seat backs adopt 4/6 split folding design. When a single seat back needs to be folded, pull up the folding handle of the rear seat back on the corresponding side.

## Adjustment of exterior rearview mirror

On the exterior rearview mirror adjustment interface in “My Car” on the center console display, adjust the exterior rearview mirror to a suitable angle.

### DANGER

- ◆ It is forbidden to adjust exterior rearview mirrors during driving.
- ◆ Object images reflected by exterior rearview mirrors are smaller than real objects, and the actual distance between the object and the vehicle will be closer than it looks. Never misestimate the distance from the following vehicle, for fear of accidents.

## Adjustment of interior rearview mirror

Before driving, it is required to adjust the interior rearview mirror to the appropriate angle.

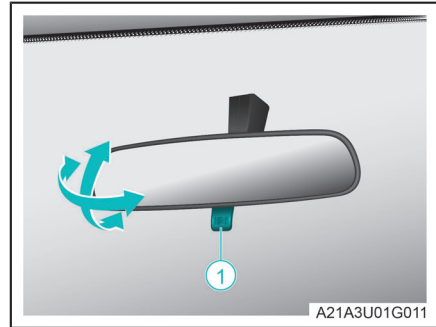

Adjust the interior rearview mirror up and down, left and right to the best rear view position.

When the lamplight of the rear approaching vehicle is dazzling, pull the flip handle ① at the lower end of the interior rearview mirror for mitigation.

### DANGER

- ◆ It is forbidden to adjust interior rearview mirror during driving.

### NOTE

- ◆ For models equipped with an automatic anti-dazzle interior rearview mirror, when the lamplight of the rear approaching model behind is dazzling, the automatic anti-dazzle interior rearview mirror will automatically adjust the mirror reflection effect to mitigate the dazzle.



## Window control

### Introduction to driver side power window buttons

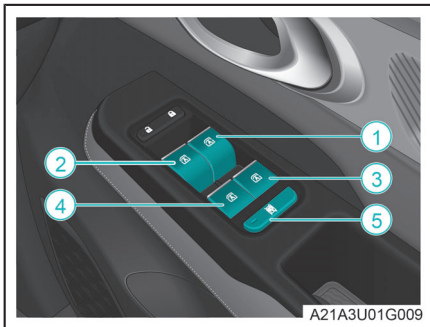

- ① Driver side power window button
- ② Front passenger side power window button
- ③ Right rear power window button
- ④ Left rear power window button
- ⑤ Passenger side window lock button

### Driver side window adjustment

Press or pull the corresponding window button gently and hold it to adjust the window to the desired position and then release the button.

Press or pull the corresponding window button beyond the pressure point and release it, to allow the window to automatically open or close completely. (One-button raising and lowering)

During one-button raising and lowering of windows, the windows can be held in current positions by operating the button.

### Passenger side window locking

Press the passenger side window lock button ⑤ to disable the passenger side window button.

Press the passenger side window lock button ⑤ again to restore the passenger side window button.

### Window anti-pinch function

If the window glass is hindered when it automatically rises, it will stop raising and immediately descend for a certain height.

#### WARNING

- ◆ The driver is responsible for the operation of all power windows, including the operation by passengers. Never allow children to operate the power windows, for fear that the power windows may pinch children or other passengers.
- ◆ When there are children in the vehicle, it is recommended that the passenger side window locking function be activated.
- ◆ During operation on windows, make sure that no part of the driver and passenger's bodies will be pinched.
- ◆ It is forbidden to test the anti-pinch function intentionally in any way.
- ◆ The anti-pinch function may not work when the window is about to close completely.

#### CAUTION

- ◆ It is forbidden to operate 2 or more windows at the same time. Otherwise, the vehicle may be damaged.
- ◆ It is prohibited to operate the same window in opposite directions by pressing the left front power window button and other passenger side power window buttons at the same time. Otherwise, the power window may stop working.
- ◆ Continuous one-button raising and lowering operation for many times in a short time may lead to temporary failure of one-button raising and lowering function.



## **i** CAUTION

- ◆ Triggering the window anti-pinch function several times in a short time will lead to the failure of the window anti-pinch function.
- ◆ When the window express-up & down or anti-pinch function fails, initialization is required to restore the function. (For details, refer to “Emergency treatment - Emergency treatment by owner - Window initialization”)

## **i** NOTE

- ◆ For some models, the opening and closing of windows can be controlled through the center console display.
- ◆ Passenger side windows are operated in the same way as the driver side window.
- ◆ After the driver leaves the vehicle, if any window is open, when the vehicle detects rain, the four windows will be automatically closed at once. (if available)
- ◆ Before entering the vehicle, you can turn on the ventilation mode in advance through the AION APP, so that the A/C can draw the external air into the vehicle. Open the windows slightly for ventilation. (if available)
- ◆ With the vehicle stationary and the gear in “P”, when the left front door is opened, if any window is open at this time, the buzzer on the instrument will sound and a relevant text prompt will be displayed.
- ◆ Before leaving the vehicle, please check that windows are closed.

## Sunroof control

### Description of sunroof buttons

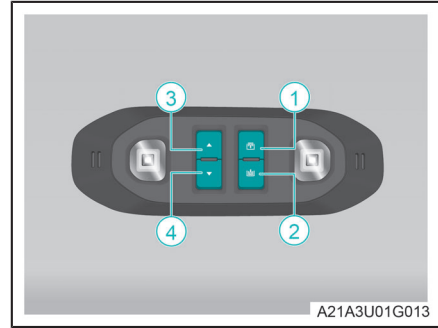

- ① Sunshade opening button
- ② Sunshade closing button
- ③ Sunroof opening button
- ④ Sunroof closing button

### Opening sunshade

Press the sunshade opening button ① to open the sunshade, and release the button to stop the sunshade.

Press and hold the sunshade opening button ①, and then release the button to enable the sunshade to open fully automatically. During movement, press the sunshade opening or closing button again to stop the sunshade.

### Closing sunshade

Press the sunshade closing button ② to close the sunshade, and release the button to stop the sunshade.

Press and hold the sunshade closing button ②, and then release the button to enable the sunshade to close fully automatically. During movement, press the sunshade opening or closing button again to stop the sunshade.





## Opening sunroof

Press the sunroof opening button  to tilt the sunroof. Press the button again to open the sunroof. And release the button to stop the sunroof.

Press and hold the sunroof opening button  to enable the sunroof to open fully automatically. During movement, press the sunroof opening or closing button again to stop the sunroof.

## Closing sunroof

Press the sunroof closing button  to close the sunroof. And release the button to stop the sunroof.

Press and hold the sunroof closing button , and then release the button to enable the sunroof to close fully automatically. During movement, press the sunroof opening or closing button again to stop the sunroof.

## Sunroof/sunshade anti-pinch function

If the sunroof/sunshade is hindered when it automatically closes, it will stop at the hindered position and immediately open for a certain distance.



### DANGER

- ◆ During driving, do not stretch any body part out of the sunroof; otherwise, severe personal injury and even death may occur due to scratching by outside objects or during emergency braking.



### WARNING

- ◆ The driver is responsible for the operation of the sunroof by all occupants. To prevent accidental operation (especially by children), do not allow children to operate the sunroof; otherwise, the sunroof may pinch children or other passengers.
- ◆ During operation on windows, make sure that no part of the driver and passenger's bodies will be pinched.
- ◆ Do not activate the anti-pinch function by pinching any part of body intentionally.
- ◆ The anti-pinch function may not work when any object is pinched by the sunroof, which is about to close completely.



### CAUTION

- ◆ Please close the sunroof; otherwise there will be a risk of water ingress on rainy days.
- ◆ If the sunroof or sunshade automatic opening and closing function fails, learning may be performed on the sunroof or sunshade according to initialization procedure to restore the automatic opening and closing function. (For details, refer to "Emergency treatment - Emergency treatment by owner - Window initialization")
- ◆ If the sunroof anti-pinch function fails, learning may be performed on the sunroof according to the initialization procedure to restore the anti-pinch function. (For details, refer to "Emergency treatment - Emergency treatment by owner - Window initialization")





## NOTE

- ◆ For some models, the opening and closing of sunroof and sunshade can be controlled through the center console display.
- ◆ The sunshade closes together with the sunroof.
- ◆ The sunroof opens together with the sunshade.
- ◆ With the vehicle stationary and the gear in "P", when the driver's side door is opened, if the sunroof is open at this time, the buzzer on the instrument will sound and a relevant text prompt will be displayed.
- ◆ After the driver leaves the vehicle, if the sunroof is open, when the vehicle detects rain, the sunroof will be automatically closed at once. (if available)
- ◆ Before leaving the vehicle, please check that the sunroof is closed.

## Steering wheel control



### ① Left buttons on steering wheel

Switching the display information on instrument

**VIEW** Switching themes of the instrument

**OK** Resetting the driving information on the instrument panel, switching alarm information

Restoring/increasing the cruising speed

Decreasing the cruising speed

Adjusting the following distance for cruise control

### ② Right buttons on steering wheel

Waking up mobile phone voice recognition function

Answering/ hanging up/ making a Bluetooth call

**MODE** Press this button to switch sound sources/ press and hold this button to pause playback

Shortcut key (customizable on the center console display)

Switch tracks/FM radio stations

Volume control



### ③ Horn sign

- Press this area to sound the horn, and release it to mute the horn.

#### NOTE

- ◆ Depending on the configuration, buttons on the steering wheel may vary. For specific buttons, the configurations of the actual vehicle shall prevail.
- ◆ Some buttons of the steering wheel can only work when certain conditions are met.

## Steering wheel adjustment

Before driving, adjust the steering wheel to the appropriate position so as to drive the vehicle more comfortably and safely.

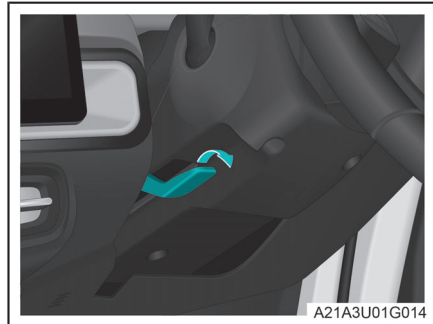

1. Unlock the steering wheel by pulling the steering wheel locking handle down.
2. Adjust the steering wheel to the desired position.
3. Pull back the steering wheel locking handle to lock the steering wheel.

#### DANGER

- ◆ It is forbidden to adjust the steering wheel during driving. Otherwise, the driver may misoperate the vehicle and cause accidents, resulting in serious injuries and even death.
- ◆ After the steering wheel is adjusted, make sure the steering wheel is firmly locked. Otherwise, the steering wheel may suddenly move and cause accidents, resulting in serious injuries and even death.



## Locking doors from inside



When doors are closed, press the locking end of the central locking switch inside the vehicle to lock all the doors.

### WARNING

- ◆ For driving safety, please lock the doors before driving.

### NOTE

- ◆ Do not frequently operate the central locking switch in a short time. Otherwise, the central locking switch may temporarily fail. In this case, after the door lock motor cools down, the central locking can be used again.
- ◆ When any door is ajar, there will be a door ajar prompt on the instrument.



## Wireless charging of mobile phone\*

### Turning on/off the wireless charging function for mobile phone

With all doors closed, touch the  button in the upper left corner of the center console display to pop up the wireless charging control interface, and turn on or off the wireless charging function on the control interface.



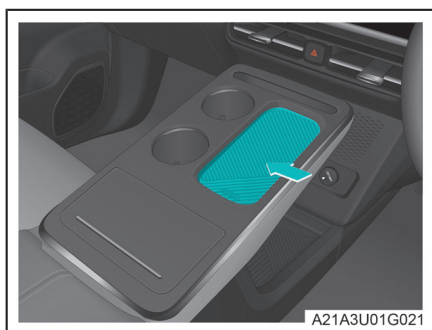

### Wireless charging of mobile phone



Place a mobile phone that supports wireless charging in the wireless charging area.

### Displaying the wireless charging status of mobile phone

The wireless charging status of mobile phone is displayed in the upper left corner of the center console display, as follows:

Icon	Status information
	Wireless charging function turned on, but no mobile phone placed there
	Charging in progress or completed
	Charging abnormal
	Wireless charging function turned off

### WARNING

- ◆ Never place any objects between the mobile phone and the charging area during charging. Non-metallic objects will cause decreased charging performance. Objects such as magnetic cards or chip cards may be damaged. Metal foreign objects such as keys and coins may be heated, posing safety risks.
- ◆ If you need to place metal objects in the storage box, please turn off the wireless charging function first to prevent the metal objects from being heated. Otherwise, it may cause safety hazards.
- ◆ While driving, it is prohibited to check the charging status of your mobile phone to avoid causing traffic accidents.
- ◆ Do not leave your mobile phone charging in the vehicle when no one is in the vehicle.

### CAUTION

- ◆ When wirelessly charging your leave phone, if there is a metal foreign object between the mobile phone and the charging area, do not remove it immediately with your hands in order to avoid burns. You should turn off the wireless charging function first and wait for the foreign object to cool before removing it.
- ◆ Do not spill liquid in the storage box to avoid damaging the wireless charging module.
- ◆ Do not place heavy objects in the wireless charging area to avoid damaging the wireless charging module.

### **i** CAUTION (Cont'd)

- ◆ When an abnormality happens to the wireless charging function, you will see a corresponding fault prompt after touching the wireless charging icon. You can follow the prompt to eliminate the fault. If it cannot be eliminated, please stop using this function and contact the GAC AION sales store for repair in time.

### **i** NOTE

- ◆ Only one mobile phone can be charged at a time.
- ◆ Wireless charging may stop when the temperature is too high, and will resume when the temperature drops.
- ◆ On bumpy roads, wireless charging may stop intermittently. If the jolt causes the mobile phone to leave the charging area, you need to put it back.
- ◆ The wireless charging function requires the interaction between the vehicle and the mobile phone. If the vehicle or mobile phone fails, charging may not be possible.
- ◆ Abnormal use (such as connecting an external wireless charging coil, etc.) or disassembly, modification, etc. of the wireless charging system will invalidate the warranty service.
- ◆ When the brake pedal is depressed and the door is closed, wireless charging may be interrupted for a short period of time.

## A/C control

### A/C quick control area

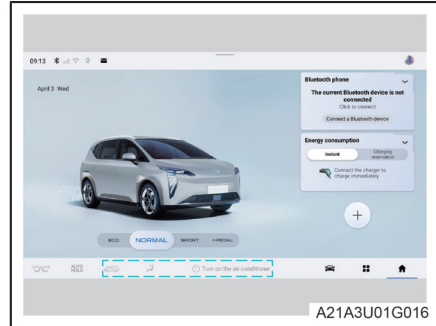

The A/C quick control area at the lower section of the center console display interface can be operated to quickly turn on the A/C. After A/C is turned on, quick control on temperature, air supply mode and recirculation/fresh air mode can be achieved.

#### Turning on and off the A/C

When the A/C is turned off, touch the “Turn on A/C” button in the quick control area of the center console display to turn on the A/C.

When the A/C is turned on, touch the button in the A/C control interface  on the center console display to turn off the A/C.

### **i** NOTE

- ◆ AUTO mode will exit when the fan speed or air supply mode is adjusted.



### A/C settings

In any interface of the center console display, touch the temperature numbers in the A/C quick control area below the center console display to enter the A/C control interface to set the A/C.

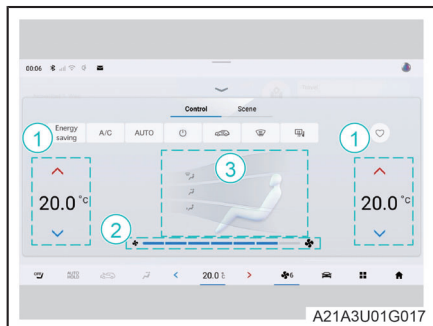

- ① Temperature control area for temperature control of A/C
- ② Air volume control area for air volume control of A/C
- ③ Air direction control area for outlet air direction control of A/C

**A/C** Turning on or off the A/C compressor

**AUTO** Turning on the auto A/C

Turning on or off the A/C

Switching the A/C recirculation/ fresh air mode

Turning on the front windshield defrost/defog function

Turning on the exterior rearview mirror defrost/defog function

**Energy saving** Turning on A/C ECO mode

### Quick heating or cooling

To achieve quick heating or cooling of cabin, select the quick cooling or heating scene in the A/C scene interface.

### One-touch disinfection\*

After turning on the remote one-touch disinfection function through the AION APP, the A/C system will purify the air in the vehicle through high temperature, filtration and other methods to create a healthy ecological cabin for you.

- ◇ When the vehicle is stationary and the battery SOC is higher than 20%, touch the "One-Touch Disinfection" button in the AION APP to enter the disinfection mode.
- ◇ Touch the "Close" button on the one-touch disinfection interface to exit the disinfection mode.

### Distribution and operation of air outlets

Front air outlet

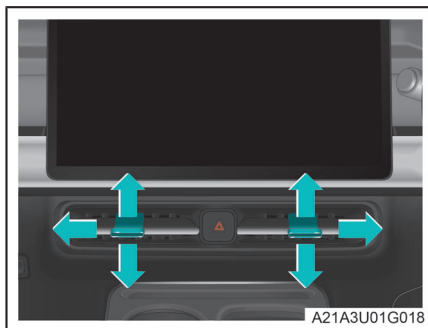

- ◇ Pull the front air outlet fork up and down, left and right to adjust the air direction of the front air outlet.
- ◇ Pull the air outlet fork left and right to the limit positions to control the air outlet to the maximum opening or close the air outlet.



## NOTE

- ◆ The control mode of the front air outlets is generally the same. Here, the front central air outlet is introduced as an example.

### Rear air outlet

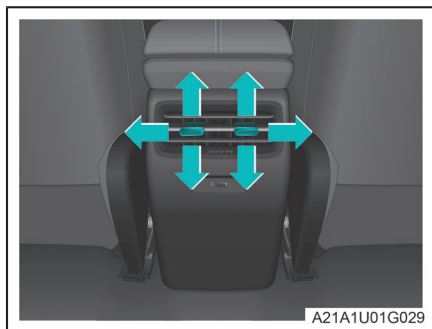

- ◇ Pull the rear air outlet fork up and down, left and right to adjust the air direction of the rear air outlet.
- ◇ Pull the air outlet fork left and right to the limit positions to control the air outlet to the maximum opening or close the air outlet.

## WARNING

- ◆ Long-term activation of recirculation mode will cause accumulation of carbon dioxide in the cabin, which is bad for keeping the driver clearheaded.
- ◆ Activation of the recirculation mode in cold or rainy days can cause the windows to mist up, affecting the driver's visibility.
- ◆ The front windshield defrost/defog function may cause the outer surface of front windshield to mist up, affecting the driver's visibility.

## WARNING

- ◆ When the front windshield defrost/ defog function is active at ambient temperature above 0°C, if the A/C compressor is turned off, the front windshield may mist up, affecting the driver's visibility.

## NOTE

- ◆ In AUTO mode, when the outlet air is at high temperature, most of the air comes out through the floor outlets; when the outlet air is at low temperature, most of the air comes out through the panel outlets.
- ◆ When the A/C is on, touch the A/C button in the center console display to make the A/C system exit the cooling mode and blow natural air.
- ◆ The temperature shown in the center console display is the target value of the temperature setting, rather than the measured inside temperature.
- ◆ To ensure the best air distribution effect, make sure that all air outlets in the cabin are open.
- ◆ For some models, the self-drying function with an evaporator can be turned on through the center console display to prevent the A/C system from damp and mold.
- ◆ After turning on the one-touch disinfection function, all doors and windows should be closed, and make sure there are no people, pets, food, or flammable items in the vehicle. (if available)
- ◆ After using one-touch disinfection in summers, it is recommended that the vehicle be left to stand for 30 minutes before you get on. (if available)



**i NOTE (Cont'd)**

- ◆ During disinfection, no other remote operations shall be performed. Please wait until disinfection is completed before performing other remote operations. (if available)
- ◆ Please download and install the AION APP in advance and register for your account to ensure the normal use of the remote one-touch disinfection function. (if available)

## Seat ventilation\*

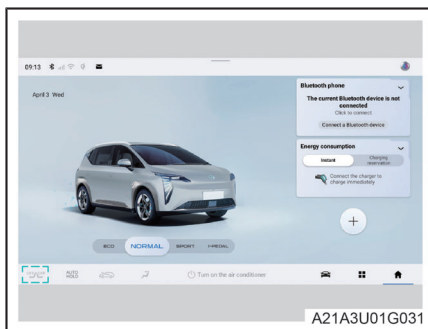

Touch the seat ventilation button on the center console display to pop up the seat ventilation setting interface, and set the seat ventilation as needed.

**i CAUTION**

- ◆ Do not kneel on the seat or apply excessive local pressure on the seat and seat back, otherwise the electrical components in the seat may be damaged.
- ◆ If there is no wind in the seat for a long time after turning on the seat ventilation function, you should immediately turn off the seat ventilation function and contact the GAC AION sales store for repair in time.

**i NOTE**

- ◆ For some models, the seat ventilation function can be controlled through the voice command.
- ◆ For some models, the seat ventilation function can be controlled remotely through the AION APP.





## Storage space

### Storage box on door interior trim panel

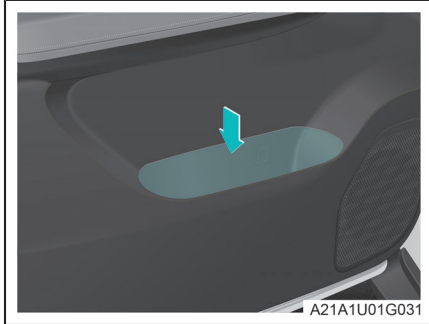

The storage box on door interior trim panel can be used to store maps, beverage bottles, etc.

### **i** CAUTION

- ◆ When storing drinks in the storage box on door interior trim panel, ensure that the drinks are sealed to prevent liquid spill during driving.

### Front central armrest box

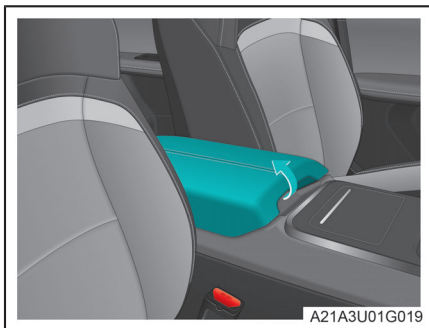

Pull up the central armrest as arrowed, and open the central armrest box.

### **!** WARNING

- ◆ During driving, make sure that the central armrest box is closed.

### Front cup holder

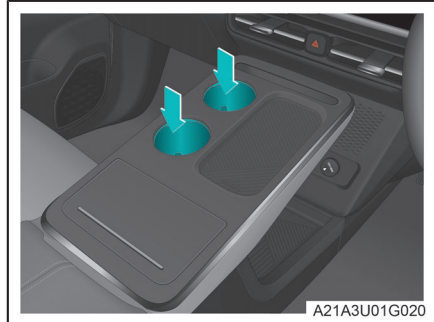

The front cup holder is used for storing cups or beverage bottles.

### **i** CAUTION

- ◆ When placing a cup or beverage bottle, ensure that it is sealed to prevent liquid spill during driving.

### Console storage box

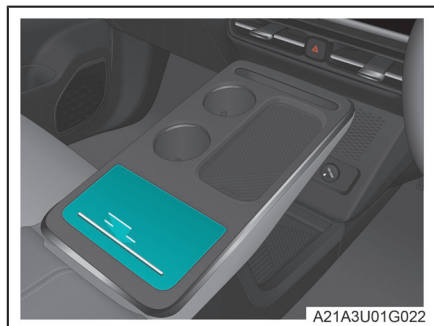

Press the area indicated by the arrow on the console storage box to open it.



Press the console storage box cover until it is locked for closing.

### Storage slot under console

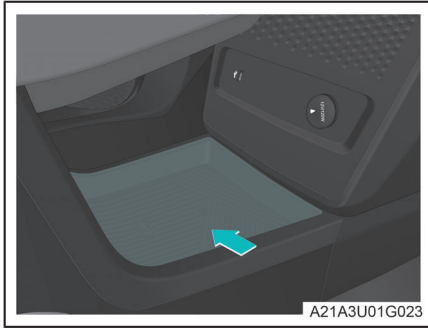

The storage slot under the console is used to store other items.

### WARNING

- ◆ Do not place any article larger than the storage slot in it.

### Glove box

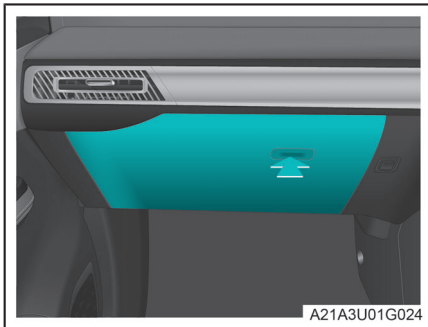

Press the glove box switch to open the glove box.

Push the glove box upward until it is latched and close the glove box.

### WARNING

- ◆ Make sure the glove box is closed during driving.

### Rear cup holder\*



The rear cup holder is in the rear center armrest. To use it, the armrest needs to be folded down first.

The rear cup holder is used for placing cups or beverage bottles.

### CAUTION

- ◆ When placing a cup or beverage bottle, ensure that it is sealed to prevent liquid spill during driving.
- ◆ Before restoring the rear center armrest, make sure there are no items in the rear cup holder.



## Safety grip

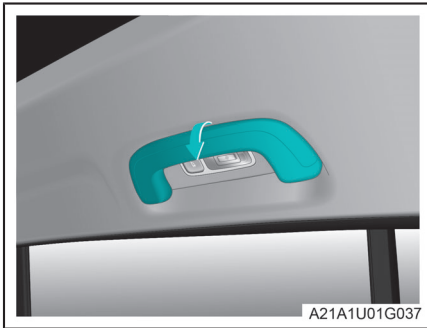

When the vehicle is running fast or on a bumpy road, the safety grips can be used to keep the body balanced.

### CAUTION

- ◆ Do not pull the Safety grip when getting on or off the vehicle or getting up from the seat.
- ◆ It is forbidden to hang any heavy objects on the Safety grips.

## Sun visor

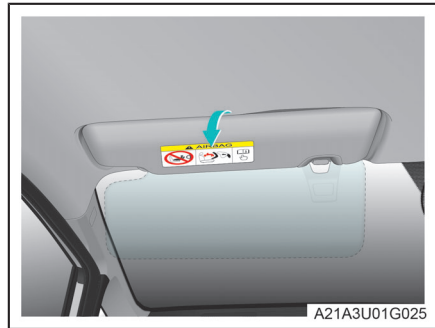

Sun visors are located above the driver's seat and front passenger's seat. Turn down the sun visor to block the dazzling light from the front.

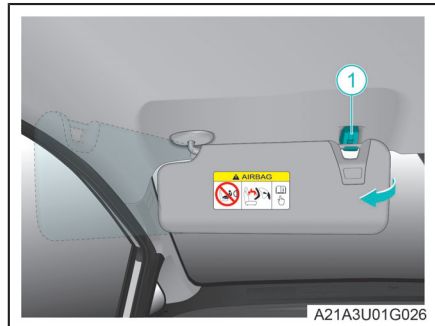

After the sun visor is turned down, disengage it from the fastening hook ① and turn the sun visor to the side window to block the dazzling light from the side.



## Vanity mirror and vanity mirror lamp

The vanity mirror and vanity mirror lamp are located on the sun visor. Turn down the sun visor and lift the vanity mirror cover to use the vanity mirror and vanity mirror lamp.

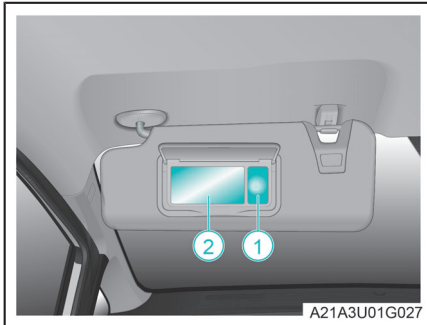

- ① Vanity mirror lamp
  - Open the vanity mirror lamp cover, so the vanity mirror lamp comes on automatically.
- ② Vanity mirror

### NOTE

- ◆ With the vanity mirror lamp on, if the vehicle is powered off or locked, the vanity mirror lamp will automatically go out after several minutes.

## 12V power outlet

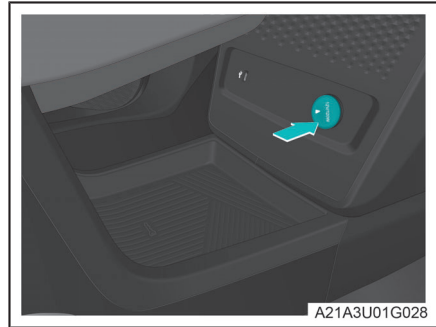

Enter the vehicle, lift the 12V power outlet cover and connect an electrical consumer at the same time to use the 12V power supply.

### WARNING

- ◆ When there is nobody in the vehicle, it is forbidden to leave the 12V power outlet in use.
- ◆ Never allow children to use or play with the 12V power outlet.
- ◆ The power outlet has the output voltage of 12V and the maximum output power of 120W. It is forbidden to connect electrical consumers of more than 120W to the power outlet.

### CAUTION

- ◆ When starting or powering off the vehicle, the electrical consumers connected with the 12V power outlet should be disconnected to avoid damaging the electrical consumers due to voltage fluctuation.
- ◆ It is forbidden to insert foreign matters into the 12V power outlet.
- ◆ It is forbidden to spill water or other liquids in the 12V power outlet.
- ◆ It is forbidden to disassemble or modify the 12V power outlet.

## USB port

### Arrangement of USB ports

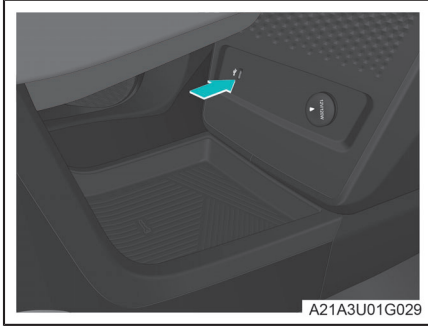

Front USB port



Rear USB port

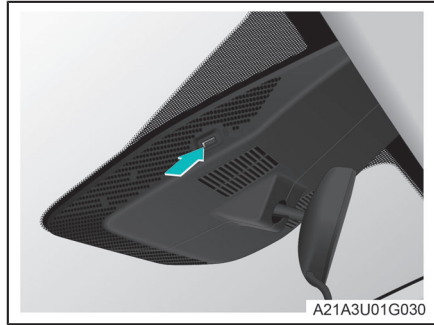

Interior rearview mirror USB port

### **i** CAUTION

- ◆ It is forbidden to insert foreign matters into USB ports.
- ◆ It is forbidden to spill water or other liquids in USB ports.
- ◆ It is forbidden to disassemble or modify USB ports.

### **i** NOTE

- ◆ The front USB port can be used for charging and reading data, while the rear USB port and the interior rearview mirror USB port can only be used for charging.



## Multimedia control panel

### Center console display



When the vehicle power is turned on, the center console display shows the initial screen for a few seconds and then starts operating.

#### **i CAUTION**

- ◆ Please do not flash the multimedia system or uninstall the apps without permission, otherwise it may cause abnormalities to the multimedia system or vehicle.
- ◆ To prevent damage to the center console display, touch the display gently during operation. If there is no response, you can try touching it again.
- ◆ When cleaning the display, do not use detergent.

#### **i NOTE**

- ◆ The buttons on the central control screen that are gray are inoperable.
- ◆ The shown interface of the center console display is for reference only, and the actual interface shall prevail.
- ◆ In order to better experience the related functions of the multimedia system, it is recommended that you connect the system to the Internet before using it.

## Basic operations

### Main interface

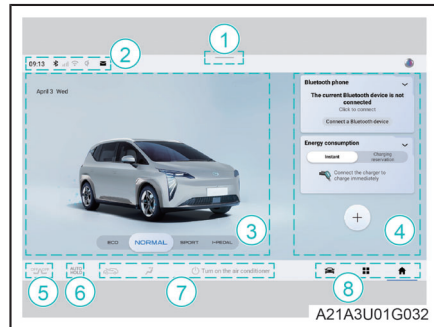

- ① Drop-down menu indication area
  - Swipe down to enter the drop-down menu bar control interface.
- ② System status bar
  - Displays system status such as "Wireless charging of mobile phone" (if available), "Bluetooth connection", etc.
- ③ Desktop scenes area
  - Allows for quick vehicle operation.
- ④ Cards area
  - Allows you to quickly enter the corresponding function interface.
- ⑤ Seat ventilation control area (if available)
  - Displays the current seat ventilation status; you can touch to enter the seat ventilation setting interface.
- ⑥ AUTO HOLD control area
  - Controls the activation and deactivation of the AUTO HOLD function.
- ⑦ A/C information display/control area
  - Displays the current A/C information; you can touch to enter the A/C setting interface.



## ⑧ System navigation bar

- Shows the soft keys for system control.

### Drop-down menu indication area

On any interface, swipe down from the top of the screen (drop-down menu indication area) to bring up the drop-down menu.



The sliding control bars can adjust the center console display brightness, media volume, call volume and navigation volume respectively. Touch the function button to turn on/off the corresponding function or enter the corresponding function interface, including entering the screen saver interface, turning off the screen, muting the sound, turning off the vehicle power, etc.

On the drop-down menu interface, touch  or swipe up from the bottom of the screen to close the drop-down menu.

### NOTE

- ◆ On the drop-down menu interface, if there is no operation, the drop-down menu will automatically collapse after a period of time.

### System status bar

The system status bar is permanently shown in the upper left corner of the center console display, including time information, data connection display, shortcuts, mobile phone wireless charging display (if available), message center shortcut, etc.

### Cards area

You can quickly enter the corresponding function interface by touching the card in the cards area of the main interface. It supports Bluetooth call card and energy consumption card. You can manually expand or collapse the card by touching its upper right corner.



- ◇ Bluetooth call card
  - When Bluetooth is not connected, touch the Bluetooth call card to jump to the Bluetooth settings interface; when Bluetooth is connected, touch the Bluetooth call card to jump to the Bluetooth call app interface.
- ◇ Energy consumption card
  - Displays the charging information; touch to jump to the energy consumption module app interface.

### Desktop scenes area

The desktop scenes area allows you to quickly set the A/C, switch driving modes, etc.

Touching the vehicle image to enter the "My Car" app interface.

### System navigation bar

- ◇ HOME button  : Touch to return to the main interface.
- ◇ Menu button  : Touch to enter the system app menu interface.
- ◇ Quick control panel button  : Touch to enter the quick control interface.

### App menu functions

Touch the menu button  on the system navigation bar of the main interface to enter the system app menu interface.





A21A3U01G034

Touch the app icon to enter the respective app interface, and touch or swipe down to hide the menu interface.

**NOTE**

◆ Due to different model configurations, the apps on the app menu interface may be different from those shown in the illustration. The actual vehicle shall prevail.

**Quick control function**

Touch the quick control panel button on the system navigation bar of the main interface to enter the quick control interface.

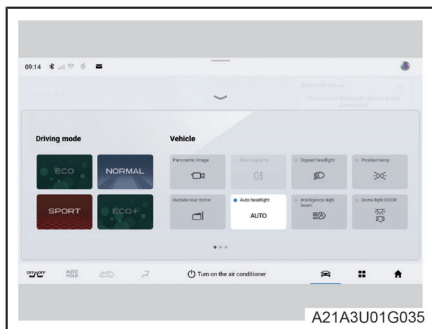

A21A3U01G035

Swipe left or right to switch pages, and touch the function buttons on the control panel to turn on/off the corresponding functions, including driving modes, ADiGO smart driving, etc.

**My Car**

Touch the vehicle image in the desktop scenes area, or the “My Car” icon on the app menu to enter the My Car interface.

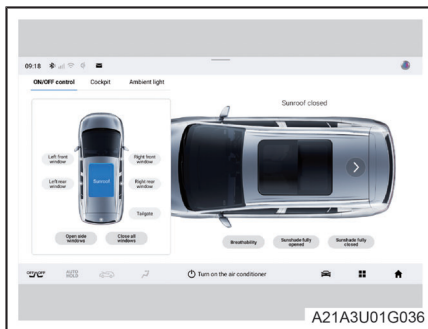

A21A3U01G036

The "ON/OFF control", "Cockpit" and "Ambient light" can be adjusted.

**Settings**

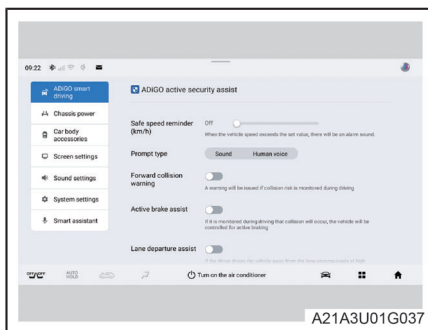

A21A3U01G037

Touch the “Settings” icon on the app menu to enter the setting interface and set various functions of the vehicle.







## Bluetooth connection

### Bluetooth connection (status 1)

This vehicle supports functions such as Bluetooth call, which can be used after successful Bluetooth connection. Operation steps of Bluetooth quick connection are as follows:

1. Turn on Bluetooth on the mobile phone.
2. Touch the Bluetooth icon  in the system status bar in the upper right corner of the center console display to enter the Bluetooth connection setting interface.
3. Touch the Bluetooth switch  to turn on Bluetooth. After the Bluetooth is turned on, the on-board unit will automatically search for nearby Bluetooth devices.
4. Touch the Bluetooth device icon to be connected and complete Bluetooth connection according to the prompts.



### Bluetooth connection (status 2)

This vehicle supports functions such as Bluetooth call, which can be used after successful Bluetooth connection. Operation steps of Bluetooth quick connection are as follows:

1. Turn on Bluetooth on the mobile phone.
2. When Bluetooth is not connected, touch the Bluetooth call card to jump to the Bluetooth setting interface.
3. Touch the Bluetooth switch  to turn on Bluetooth. After the Bluetooth is turned on, the on-board unit will automatically search for nearby Bluetooth devices.
4. Touch the Bluetooth device icon to be connected and complete Bluetooth connection according to the prompts.

### Bluetooth call

Answering or hanging up

- ◇ When there is an incoming call, press the button  on the steering wheel to answer the call; press and hold the button  on the steering wheel to decline the call.

- ◇ At the end of the call, press and hold the button  on the steering wheel to hang up the call.

Making a call

- ◇ After Bluetooth connection, enter the Bluetooth call interface, and then dial a number directly, touch the contact number to make a call or search a contact to make a call.



## Voice assistant\*

### Using voice assistant

Short press the button  on the steering wheel or say the wake-up word "Hello baby" to wake up the voice assistant.

After waking up, the voice assistant will answer by saying "Please speak" and the word "Listening" appears on the interface. Say the operation you want (such as, I want to listen to music). The voice assistant will recognize and execute the voice command to quickly control the vehicle function, improving operational convenience.

### Voice command

The following functions or systems can be conveniently controlled through the voice assistant:

Category	Function	Example
Navigation	Navigating to destination	Navigate home, go to work, I want to go to RT-Mart, navigate to KFC, etc.
	Checking the traffic conditions	Show the traffic conditions, show the real-time traffic conditions, display the traffic conditions, etc.
	Checking the types of nearby facilities	Nearby charging piles, check nearby charging piles, nearby hotels, etc.
Bluetooth	Call	Call Zhang San, call Li Ming, dial 10086, find xxx's phone number, call back, etc.

Category	Function	Example
Multimedia	Radio stations	I want to listen to FM xxx, listen to Yangcheng Traffic Radio, listen to music radio, save the radio station as my favorite, etc.
	Music	I want to listen to songs, play "Rainbow", Li Jian's songs, listen to the album Fantasy, play, pause, continue playing, loop play, etc.

### NOTE

- ◆ The success rate of speech recognition will be affected by environmental noise, network signals, usage habits, pronunciation and other factors. The specific use results are subject to the actual usage environment.
- ◆ The voice control function varies by model. The functions listed in this table are for reference only. The actual vehicle should prevail.



## Connection with mobile phone\*

### CarPlay

Apple CarPlay allows you to use iPhone in the vehicle intelligently and safely, and enables the vehicle multimedia system to share the functions of mobile phones such as navigation, music, call, etc.

- ◇ Connection between mobile phone and on-board unit
  1. Touch the Apple CarPlay icon on the center console display to enter the mobile phone and on-board unit interconnection guide.
  2. Set CarPlay as the priority connection app for iPhone on the center console display.
  3. Connect the mobile phone with the on-board unit via an original USB cable or wireless connection (if available).
  4. Run CarPlay APP to connect it to the mobile phone.
- ◇ Exit method
  - CarPlay may be exited by either of following ways:
    - Unplug the USB cable or disconnect the wireless connection (if available).
    - Shut down the CarPlay on the mobile phone.

### NOTE

- ◆ The specific functions of CarPlay depends on the actual condition, and generally include navigation, music, call, etc.
- ◆ When connecting your iPhone to the vehicle, please use the original data cable, otherwise the connection may fail.
- ◆ Only iPhones with iOS 10.0.2 and higher support connection with CarPlay.

### Android Auto

Android Auto enables the vehicle multimedia system to share the functions of mobile phones such as navigation, music, call, etc.

- ◇ Downloading of mobile phone application
  - Android Auto may be downloaded from the APP Store on the mobile phone.
- ◇ Connection between mobile phone and on-board unit
  1. Connect the mobile phone with the on-board unit with an original USB cable.
  2. Run Android Auto.



## Precautions for multimedia use

Read and observe the following when using the multimedia system.

### WARNING

- ◆ Be sure to pay full attention during driving, and do not operate or check the multimedia system too frequently. Otherwise, the driver is prone to distraction, causing serious traffic accidents.
- ◆ During driving, reduce the multimedia volume in the cabin to listen to the warning sound outside. Otherwise, traffic accidents may occur.
- ◆ During route navigation through the navigation system, please drive according to actual traffic rules. Completely following the route planned by the navigation system during driving may violate traffic rules sometimes, which can cause traffic accidents.
- ◆ Do not operate the multimedia system in no-parking areas. Otherwise, traffic accidents may occur.
- ◆ It is forbidden to disassemble, modify or destroy the multimedia system without authorization. Otherwise, problems such as system failure, fire and electricity leakage may occur.
- ◆ Keep the multimedia system dry, and avoid liquid ingress. Otherwise, multimedia system may fail and even fire can occur.
- ◆ If the multimedia system fails, do not repair it without authorization. Stop using it and contact the GAC AION sales store for repair.
- ◆ Do not use the center console display in a faulty state without images or sounds.

### CAUTION

- ◆ When cleaning the screen, please turn off the multimedia system first, and then clean it with a soft dry cloth. Do not use hard cloth, chemical cloth or organic solvent (benzene, ethanol, paint thinner, etc.) to clean the screen. Otherwise, the screen may be damaged.
- ◆ Do not knock or press the center console display hard when operating it. Otherwise, the screen may be damaged.
- ◆ Do not use sharp or angular hard objects to operate the center console display. Otherwise, the screen may be damaged.
- ◆ Do not plug and unplug USB devices repeatedly in a short time. Otherwise, USB devices may be damaged.
- ◆ The amount of time for identifying a USB device is affected by the type, capacity, or stored file format of the USB device.
- ◆ Do not store too many unnecessary files in USB devices. Otherwise, the recognition speed will be affected.
- ◆ If heat is generated during charging with USB ports, charging performance may be reduced or failure may occur.
- ◆ SD type USB memory stick, CF type USB memory stick, or other USB devices used to connect the adapter may not be recognized.
- ◆ USB devices may not be recognized by a common USB cable or extension cable. Please connect the USB devices directly to the USB port for use.
- ◆ Vehicle vibration may cause poor contact of USB devices.

### CAUTION (Cont'd)











- ◆ During media playing with USB devices, the opening time of different video and image files may vary. For example, image files that occupy more storage space, and high-resolution video and audio files take more time to open. That it takes too long time to open a file may cause the system to restart.
- ◆ Fast forward and rewind of video are based on addressing by frames. The data formats of converted video files may not be standard. There may be irregular fast forward, rewind and even seizure during video playing. Or, some key frames are lost after conversion, which may lead to seizure and restart.

### NOTE













- ◆ Do not dismantle, modify or destroy the multimedia system without authorization. Otherwise, the product warranty may be invalidated.
- ◆ As USB devices may have compatibility problems, the multimedia system cannot recognize all USB devices. In such cases, please replace the USB devices and try again.
- ◆ The multimedia system of this vehicle only supports USB devices with FAT16/32 file type.
- ◆ As the multimedia system features video playback limitation during driving, it is impossible to watch video during driving. The video playback limitation can be disabled through the center console display. For driving safety, please keep this function enabled during driving.



## Indicator lamps on instrument

Name	Icon	Description
Left turn signal indicator lamp		The indicator lamp comes on if the left turn signal lamp is turned on
Right turn signal indicator lamp		The indicator lamp comes on if the right turn signal lamp is turned on
Position lamp indicator lamp		The indicator lamp comes on if the position lamps are turned on
Rear fog lamp indicator lamp		The indicator lamp comes on if the rear fog lamp is turned on
High beam indicator lamp		The indicator lamp comes on if the high beam is turned on
READY indicator lamp		If the indicator lamp comes on, it indicates that the vehicle has started and gears can be shifted
Driver's seat belt warning lamp		The indicator lamp comes on to remind the driver to fasten the seat belt
Front seat belt warning lamp		The indicator lamp comes on to remind the front passenger to fasten the seat belt
Charger on indicator lamp		If the indicator lamp comes on, it indicates that the charger is successfully connected with the vehicle charging port
AUTO HOLD status indicator lamp		If the indicator lamp comes on, it indicates that the AUTO HOLD is activated
Electric park brake (EPB) status indicator lamp		If the indicator lamp comes on, it indicates that EPB is applied



Name	Icon	Description
Scheduled charging indicator lamp		With the charger connected, when "Scheduled Charging" has been set but the scheduled charging has not started, the indicator lamp comes on.
		With the charger connected, when "Scheduled Charging" has been set and the scheduled charging is in progress, the indicator lamp comes on.
Cruise control indicator lamp		The indicator lamp comes on when the cruise control function is activated
		If the indicator lamp comes on, it indicates that the vehicle is in cruise control state
ACC indicator lamp (no vehicle ahead)		If the indicator lamp comes on, it indicates that ACC is ready and there is no target vehicle ahead
		If the indicator lamp comes on, it indicates that ACC is active and there is no target vehicle ahead
ACC indicator lamp (vehicle ahead)		If the indicator lamp comes on, it indicates that ACC is ready and there is a target vehicle ahead
		If the indicator lamp comes on, it indicates that ACC is active and there is a target vehicle ahead
Lateral control indicator lamp		If the indicator lamp comes on, it indicates that ICA is ready
		If the indicator lamp comes on, it indicates that the lateral control of ICA is activated
Hands Off indicator lamp		If the indicator lamp flashes, it indicates that the driver's hands are detected to be off the steering wheel
FCW status indicator lamp		If the indicator lamp flashes, it indicates that FCW is activated



Name	Icon	Description
LDW status indicator lamp		If the indicator lamp comes on, it indicates that the LDW is in ready state
		If the indicator lamp comes on, it indicates that the LDW is active
Intelligent high beam status indicator lamp		If the indicator lamp comes on, it indicates that the Intelligent High Beam Control (IHBC) is activated

**NOTE**

- ◆ Refer to the corresponding sections for the detailed functional status of some indicator lamps on the instrument.
- ◆ Some indicator lamps on the instrument are only displayed on vehicles with relevant configurations. The actual vehicle shall prevail.









## Warning lamps on instrument

Name	Icon	Description
ABS indicator lamp		If the indicator lamp comes on, it indicates that the ABS is faulty.
SRS warning lamp		If the indicator lamp comes on, it indicates that the SRS is faulty.
ESP indicator lamp		If the indicator lamp comes on, it indicates that the ESP is faulty.
Low voltage battery fault warning lamp		If the indicator lamp comes on, it indicates that the 12V low voltage system is faulty.
Low battery indicator lamp		If the indicator lamp comes on, it indicates that the traction battery is too low
EPS indicator lamp		If the indicator lamp comes on, it indicates that the EPS is faulty (the red indicator lamp comes on for some models).
EPB fault indicator lamp		If the indicator lamp comes on, it indicates that the EPB is faulty.
Lateral control indicator lamp		If the indicator lamp comes on, it indicates that the ICA is faulty.
FCW status indicator lamp		If the indicator lamp comes on, it indicates that the FCW is faulty.
LDW status indicator lamp		If the indicator lamp comes on, it indicates that the LDW is faulty
Cruise control fault indicator lamp		If the indicator lamp comes on, it indicates that the ACC is faulty.



Name	Icon	Description
Electric power system fault indicator lamp		If the indicator lamp comes on, it indicates that the electric power system is faulty.
Parking brake and brake system indicator lamp		If the indicator lamp comes on, it indicates that the brake fluid level in the front compartment is low.
Reduced-power indicator lamp		If the indicator lamp comes on, it indicates that the powertrain of the vehicle is overheated or faulty, and the vehicle is running at reduced power
TPMS indicator lamp		If the indicator lamp comes on, it indicates that the TPMS is faulty.

### NOTE

- ◆ Self-test will be carried out when the vehicle starts, and some warning lamps on instrument will come on for a short time and then automatically go out. If some warning lamps on the instrument are still on after the vehicle starts, please contact the GAC AION sales store for repair in time according to the actual situation.
- ◆ Some warning lamps on the instrument are only displayed on vehicles with relevant configurations. The actual vehicle shall prevail.

## Instrument view

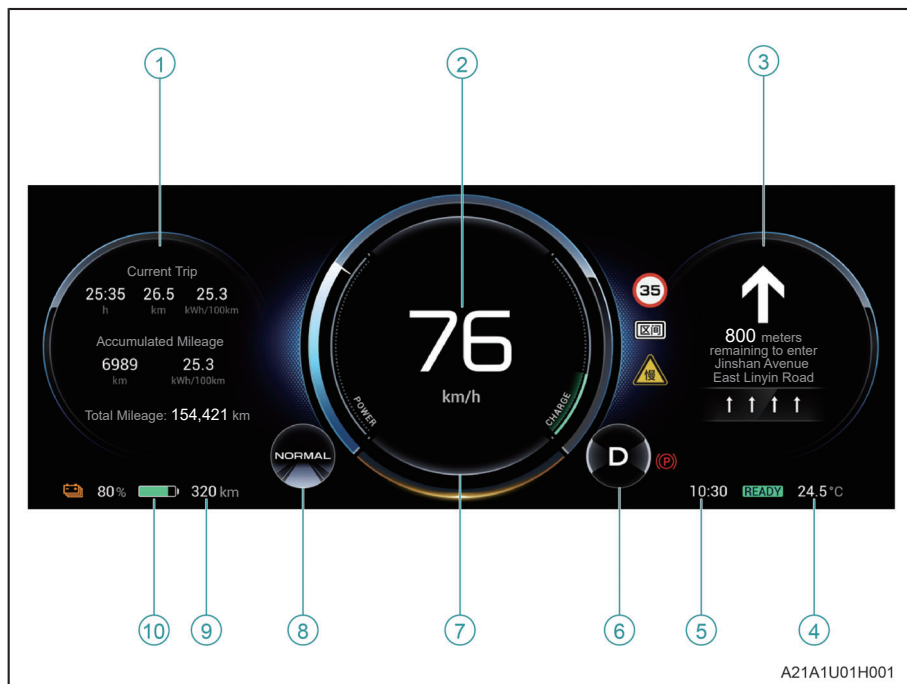

- |                                   |                            |
|-----------------------------------|----------------------------|
| ① Left information display        | ⑥ Gear information         |
| ② Vehicle speed information       | ⑦ Power information        |
| ③ Right information display       | ⑧ Driving mode information |
| ④ Ambient temperature information | ⑨ Range                    |
| ⑤ Time information                | ⑩ Battery SOC information  |

**NOTE**

- ◆ The instrument has many display styles. Please refer to the actual vehicle.

### Left information display

This area shows information such as power consumption and charging condition.

### Vehicle speed information

#### NOTE

- ◆ According to laws and regulations, the speed indicated on the instrument is generally greater than the actual speed.

### Right information display

This area shows information such as navigation and music synchronized with the center console display.

### Power information

This area shows current power output or energy recovery condition.

### Driving mode information

This area shows the current driving mode of the vehicle.

### Battery SOC information

This area shows the current SOC of the battery.

## Information display

Information shown on the left information display includes power consumption, alarm, mileage, door status, tire pressure monitoring, driving assistance (if configured), charging, radar alarm, etc. Please switch the corresponding display information according to the actual vehicle.

The information display on the right side shows information such as navigation and music synchronized with the center console display. Please refer to the actual vehicle.

### Adjusting buttons on left information display of instrument

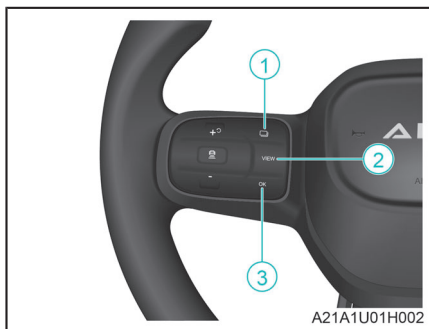

- ① Page-turning button
- ② VIEW theme switching button
- ③ OK button

How to switch the left information display page of the instrument

Press the paging button on the steering wheel to switch the left information display page of the instrument.

- ◇ Driving assistance information page (if available)
  - Information related to driving assistance (e.g., ACC, FCW) like pedestrian, vehicle and target obstacle in front of the vehicle is displayed. Please refer to the actual vehicle.

- ◇ Charging information page
  - When the vehicle is being charged, the charging information is displayed. This page can only be viewed when the vehicle is being charged.
- ◇ Radar alarm information page
  - This page displays the radar alarm information. This page is displayed only when an obstacle is detected around the vehicle.

### How to switch the instrument display theme

Press the VIEW theme switching button on the steering wheel to switch the instrument display theme. For specific display style, please refer to the actual vehicle.

### How to reset the accumulated mileage

1. Switch the left information display page of the instrument to the mileage information page.
2. Press and hold the OK button on the steering wheel to reset the accumulated mileage value.

#### NOTE

- ◆ The total mileage of the vehicle cannot be reset.

### How to view alarm messages

1. When an alarm message appears, the alarm message pops up on the instrument. After confirmation, press the OK button on the steering wheel, so the alarm message is transferred to the alarm center.
2. Press the page turning button on the steering wheel to switch the left information display page to the alarm center.
3. On the alarm center page, press the OK button on the steering wheel to switch to and view different alarm messages.

#### NOTE

- ◆ On the alarm center page, other information on the left information display can be switched and viewed by pressing the page turning button on the steering wheel.

### How to set the volume, units and brightness of the instrument

As for the setting items of the center console display, set the volume, units and brightness of the instrument.

#### WARNING

- ◆ During operation on the instrument information display during driving, special attention should be paid to the safety of surrounding areas of the vehicle.
- ◆ During driving, do not keep looking at the information display on the instrument. Otherwise, you may not see pedestrians and objects on the road in front of the vehicle, resulting in accidents.

#### CAUTION

- ◆ If the information display is abnormal, stop the vehicle immediately in a safe way, and contact the GAC AION sales store for repair.



## Tire Pressure Monitoring System (TPMS)

The vehicle is equipped with a TPMS, which can monitor and issue alarms about the tire pressure.

### TPMS alarm

The TPMS issues an alarm when any of the following conditions occurs:

- ◇ Tires of specified specifications are not used.
- ◇ Tires leak rapidly due to a puncture, etc.
- ◇ Tires leak slowly for a long time.
- ◇ One or more tires are underinflated.
- ◇ The vehicle is driven when a non-full-size spare tire or a tire chain is installed.
- ◇ The road condition is too poor or the vehicle is driven unconventionally for a long time.

### How to view TPMS alarm messages

When the TPMS indicator lamp  comes on, you can switch the instrument information display page to the tire pressure monitoring information page via the page turning button on the steering wheel, so as to view the detailed information.

### Initialization of the TPMS

To ensure normal operation of the TPMS, the TPMS shall be initialized when any of the following conditions occurs:

- ◇ The pressure of one or more tires is adjusted.
- ◇ One or more tires/wheels are replaced, reinstalled or subjected to dynamic balancing again.
- ◇ Tire rotation
- ◇ The chassis or vehicle suspension is changed or adjusted.
- ◇ It has been more than a year since the last initialization.

- ◇ The difference between the current ambient temperature and the ambient temperature during the last initialization is great.

### How to initialize the TPMS

1. Adjust all the tire pressure to the standard value.
2. Press the page turning button on the steering wheel to switch the instrument information display page to the tire pressure monitoring page.
3. Press and hold the OK button on the steering wheel for a long time to initialize the TPMS.

### NOTE

- ◆ After Initialization of the TPMS, a relevant warning message will be displayed on the instrument.
- ◆ In case of initialization failure, contact the GAC AION sales store for repair.
- ◆ After successful initialization, the TPMS can work properly only after the vehicle is driven for a certain distance normally.



### Precautions for the TPMS

Read and observe the following precautions when using the TPMS.

#### WARNING

- ◆ Do not rely entirely on the TPMS. Check the tire status regularly to ensure that the tire pressure is normal and tires are free of damage, e.g. puncture, cut and crack.
- ◆ If the indicator lamp of the TPMS comes on, be sure to slow down the vehicle immediately, avoid sharp turns and emergency braking, stop the vehicle safely nearby, and check the tire status as soon as possible.
- ◆ The Initialization of the TPMS is prohibited in the non-standard tire pressure status; otherwise, tread cracking, tire burst or other faults may occur due to too low tire pressure, thus affecting the driving safety.

#### CAUTION

- ◆ If the TPMS fault occurs repeatedly, contact the GAC AION sales store for repair.

#### NOTE

- ◆ If the tire pressure is higher than the standard value, the TPMS may be unable to give an alarm.
- ◆ The TPMS will not display the actual tire pressure.
- ◆ Only tire pressure adjustment without initialization cannot eliminate the tire pressure alarm.



## Vehicle start

Normally, the vehicle may be started as follows:

1. Carry the smart key with you and enter the vehicle. Then close all doors and fasten the seat belt.
2. Depress and hold the brake pedal.
3. Move the column shifter to select the desired gear.
4. Release the brake pedal after the READY indicator lamp **READY** on the instrument comes on and the vehicle is started and ready for driving. Then the vehicle will drive in the selected gear.

### NOTE

- ◆ Lock all doors before starting the vehicle and never open any door during driving.

## Switching of driving modes

This vehicle allows multiple driving modes, which can be switched according to specific application scenarios.

### Switching of driving modes

After the vehicle power supply is switched on, switch the driving modes through the center console display.

- ◇ ECO mode
  - Smooth dynamic response and longer range.
- ◇ NORMAL mode
  - Moderate dynamic response, high ride comfort and moderate range.
- ◇ SPORT mode
  - Fast dynamic response, greater driving pleasure and maximum acceleration.
- ◇ I-PEDAL mode
  - The I-PEDAL mode refers to the one-pedal mode, where acceleration, deceleration and braking operation may be carried out by depressing, lifting and completely releasing the accelerator pedal. In this mode, energy recovery rate is high and the range of vehicle can be significantly improved. This mode is especially suitable for urban roads.

### CREEP mode\*

After the I-PEDAL mode is activated, the CREEP mode can be activated or deactivated through the center console display. After the CREEP mode is activated, start the vehicle, shift to the "D" gear, release the parking brake and release the brake pedal. In this case, the vehicle can creep slowly without depressing the accelerator pedal.





### Braking energy recovery\*

The braking energy recovery converts a part of kinetic energy during vehicle braking or coasting into the electric energy of traction battery, thus extending the range of vehicle.

The driver can set the braking energy recovery level through the center console display. The higher the energy recovery level, the greater the energy recovery rate, and the stronger the braking feel of releasing the accelerator pedal during driving.

In the ECO, NORMAL or I-PEDAL mode, the braking energy recovery level can be selected as needed. In the SPORT mode, the braking energy recovery level is unadjustable, and low by default.

#### WARNING

- ◆ The speed reduction caused by the I-PEDAL mode cannot completely replace normal braking. In an emergency, please depress the brake pedal in time.
- ◆ When the vehicle runs on a steep slope, the CREEP function may not ensure slow driving.
- ◆ In this case, please depress the brake pedal to prevent sliding on the slope. The driver is responsible for paying attention to the state of the vehicle, otherwise a traffic accident may occur.
- ◆ After the vehicle is stopped through the I-PEDAL mode, the driver is strictly forbidden to leave the vehicle before the vehicle is parked safely.

#### WARNING (Cont'd)

- ◆ The I-PEDAL mode cannot be used for long-time parking. For long-time parking, set the gear to "P".
- ◆ The speed reduction caused by the energy recovery cannot replace normal braking. Depress the brake pedal during deceleration or parking.
- ◆ During driving on icy and snowy roads, use the energy recovery function cautiously to prevent vehicle slip caused by the energy recovery.

#### NOTE

- ◆ In I-PEDAL or ECO mode, the power is limited and may not allow the vehicle to reach the highest speed.
- ◆ In some cases, the driving mode may be switched automatically. For example, in ECO mode, when the vehicle is climbing a steep slope or under insufficient power, the vehicle will automatically switch to NORMAL mode.



## Shifting gears

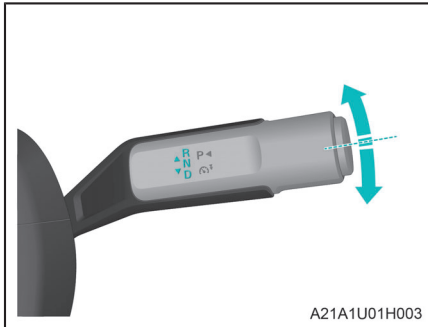

P: Parking gear

R: Reverse gear

N: Neutral gear

D: Drive gear

Switch on the vehicle power supply, close the doors, fasten the seat belt, depress the brake pedal, and move the column shifter to select the desired gear. After the gearshifting, the current gear information will be displayed on the instrument.

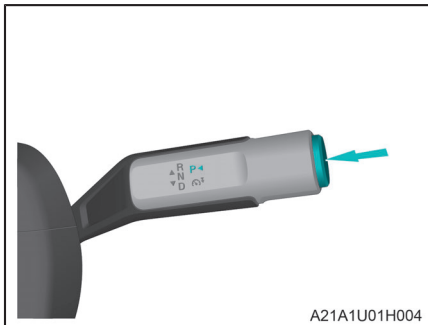

After the vehicle comes to a full stop, press the “P” button to shift to “P” gear. Then the EPB is automatically enabled.

### WARNING

- ◆ Never allow the vehicle to coast in neutral gear.
- ◆ During temporary stop in “N” gear, be sure to apply the parking brake or step on the brake pedal; otherwise the vehicle may slide, causing an accident.

### NOTE

- ◆ For shifting from “D” or “R” into “N”, the column shifter shall be moved and held for no less than 2s. Otherwise, shifting to “N” will fail.

## Pedals

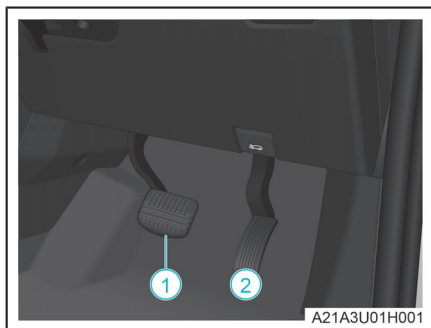

- ① Brake pedal
- ② Accelerator pedal

### WARNING

- ◆ Never place any items in the driver's footwell to prevent sliding into the pedal area, hindering the driver to operate the pedal, and thus resulting in a traffic accident.
- ◆ Before driving the vehicle, be sure to check that all pedals can be depressed to the floor and released smoothly at any time.
- ◆ The driver must wear suitable shoes which are sensitive to pedal movement.
- ◆ Never rest your foot on the brake pedal while driving the vehicle; otherwise the brake temperature will rise abnormally and the brake linings will wear excessively, increasing the braking distance.
- ◆ Continuous application of the brake will cause brake overheating and result in braking performance degradation and even braking failure.

### NOTE

- ◆ In case of braking circuit failure, the brake pedal requires longer pedal travel to stop the vehicle.
- ◆ When the vehicle climbs down a long or steep slope, it is recommended to activate the I-PEDAL mode to brake with the drive motor and reduce the brake load.



## Brake assist control systems

### Service brake

#### CAUTION

- ◆ If sharp metallic friction sound is emitted during braking, the brake linings may be close to the wear limit, and it is recommended to contact the GAC AION sales store for inspection in time.
- ◆ If the vehicle vibrates or buffets continuously during braking, it is recommended to contact the GAC AION sales store for inspection in time.

#### NOTE

- ◆ Under certain driving and weather conditions, squeaks, screams, or other noises may be heard from brakes when the brake pedal is depressed for the first time or lightly stepped on, or braking noise during light or moderate braking, especially for new vehicles (as their brakes have not undergone running-in), which is normal, and does not constitute a failure symptom of braking system nor has effects on the braking safety and performance.
- ◆ Under normal driving conditions, the dust accumulation due to brake wear will not affect the braking performance.
- ◆ If rust and corrosion exist because the brake linings and brake discs are not used or used rarely, noise may be heard from brakes for the first use. This is normal. Safe areas and good road conditions are recommended for braking the vehicle several times to clean the brake linings and brake discs.

### Anti-lock Braking System (ABS)

The ABS prevents wheel lockup when you apply the maximum braking force. Under most of the road conditions, the steering control performance of the vehicle can be improved during emergency braking.

During emergency braking, the ABS continuously monitors the speed of each wheel and automatically adjusts brake pressure according to the lockup state.

During operation of the ABS, you may perceive the brake pedal vibration, which indicates that the ABS is working and is normal.

#### WARNING

- ◆ The driver should always maintain the safety distance from the vehicle ahead and master the dangerous situation during driving. Although ABS can improve the braking distance, it cannot go beyond the physical law, and also cannot prevent the danger due to tire slip (when the water layer between the road surface and the tire prevents direct contact between the tire and road surface).

### Electronic Brakeforce Distribution (EBD)

During normal braking, the EBD balances the distribution of braking force on front and rear wheels according to the vehicle load, in order to achieve the shortest braking distance under the premise of stable braking. This improves the stability and operability of the vehicle during braking, especially during driving on poor or wet and slippery roads.

### Electronic Stability Program (ESP)

The ESP determines the driving intention of the driver according to the steering wheel angle and the vehicle speed, and compares it with the actual driving condition of the vehicle continuously. In case of departure from normal driving route (such as in case of sideslip), the ESP makes correction by applying braking force and limiting torque output to the corresponding wheel to ensure the stability of the vehicle.



## Hill Hold Control (HHC)

The HHC is mainly used to help the driver to pull away successfully on a steep slope.

When the vehicle is stationary, the HHC detects whether the vehicle is on a slope through the longitudinal acceleration sensor. Subsequently, when the vehicle goes up the slope from the stationary state (through forward traveling or reversing), the HHC will automatically enter the working state. At start, when the driver releases the brake pedal, the HHC will maintain the previous brake pressure to ensure that the vehicle remains still and gradually reduce the brake pressure with the increase of driving torque to realize the effect that the vehicle does not slide in the opposite direction without application of parking brake, which greatly facilitates vehicle starting and pedal operation.

On the premise of meeting the following conditions, if the driver depresses the brake pedal with the vehicle stopped, the HHC is activated:

- ◇ The accelerator pedal is not depressed.
- ◇ The vehicle is stationary.
- ◇ The EPB is not applied.

## Hydraulic Brake Assist (HBA)

The HBA assists the driver in emergency braking. It determines whether full braking is required based on the speed at which the driver depresses the brake pedal. As long as the driver depresses the pedal to the floor all the time, the HBA will automatically increase the braking force to the threshold at which the ABS activates. If the driver releases the brake pedal, the HBA will reduce the braking force to the specified value.

## Hydraulic Boost Failure Compensation (HBC)

The HBC controls the vehicle to achieve a large braking deceleration through active pressurization via the ESP in case of failure in the vacuum-assisted brake system.

### Braking mode\*

The braking mode can be set in the center console display.

- ◇ Standard: moderate pedal effort during braking.
- ◇ Sport: greater moderate pedal effort and steady foot feel.

### WARNING

- ◆ Always adjust the vehicle speed according to weather, road and traffic conditions. Never risk driving merely by virtue of the additional safety functions provided by the brake assist control systems, so as to prevent accidents.
- ◆ The ESP cannot go beyond the physical limit of road adhesion; be careful during driving on a wet and slippery road or with a trailer coupled.
- ◆ The driver should adjust the driving style at any time according to the road and traffic conditions.



## CAUTION

- ◆ Improper operation or modifications (such as modifications to the brake system, wheels, tires and other components) of the vehicle will affect the functions of the ESP and ABS.
- ◆ Tires of specified specifications and size must be used. If the tire size is incorrect, or the size of the tires is inconsistent, the ABS may not function.

## NOTE

- ◆ In case of failure in the ABS, the normal braking system can still work normally, but braking characteristics have changed.

## Acoustic Vehicle Alerting System (AVAS)

During driving at low speed, the AVAS sounds the warning chime to warn pedestrians and vehicles to improve driving safety.

The system sounds the warning chime when the vehicle runs forward at the speed of not more than 25km/h or reverses.



## AUTO HOLD

The AUTO HOLD can help you keep the vehicle stationary after the braking, without the need of setting the gear to “N” / “P” or apply the parking brake. When you need to drive again, just depress the accelerator pedal.

### Activation conditions

When the following conditions are met, the AUTO HOLD can be activated:

- ◇ The vehicle has been started.
- ◇ The driver has fastened the seat belt.
- ◇ All doors have been closed
- ◇ The vehicle is stationary.

### Activating and deactivating the function

After the activation conditions of the function are met, touch the AUTO HOLD button on the center console display to activate or deactivate the AUTO HOLD function. After this function is activated, the AUTO HOLD button turns green.

### Use of AUTO HOLD

With AUTO HOLD activated, after braking through depressing the brake pedal, the indicator lamp (P) on the instrument will come on, indicating that AUTO HOLD is working. At this time, if the brake pedal is released, the vehicle will remain stationary, and after the accelerator pedal is depressed, the vehicle will resume driving.

### WARNING

- ◆ When AUTO HOLD is in operation, opening the driver’s door or unfastening the driver’s seat belt will deactivate the function.
- ◆ When AUTO HOLD is in operation, operating the EPB manually will deactivate the function.

### CAUTION

- ◆ When driving into a mechanism such as a vehicle washing device that transports the vehicle with a conveyor belt, be sure to deactivate the AUTO HOLD.



## Light control

### Activating automatic headlamp function

Switch on the vehicle power supply, touch the button on the center console display to enter the quick control interface and then touch the automatic headlamp button to turn on the automatic headlamp function.

If the automatic headlamp function is activated, the position lamp and the low beam will be turned on or off automatically according to the ambient light.

### Turning on headlamps

The headlamp is an important illumination tool for nighttime driving. Please turn on the headlamps during nighttime driving.

The headlamp consists of a low beam and a high beam, which should be switched reasonably according to the actual road condition and the driving environment.

Switch on the vehicle power supply, touch the button on the center console display to enter the quick control interface and then touch the low beam button to turn on the low beam.

If the automatic headlamp function is activated, the low beam will be turned on or off automatically according to the ambient light.

### Headlamp aiming

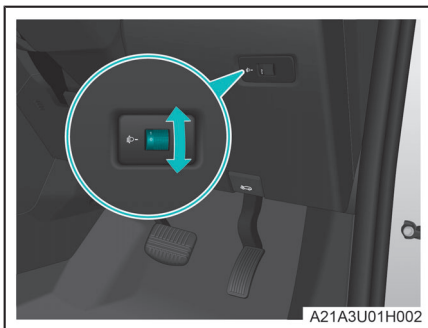

According to the actual vehicle condition, the low beam height can be adjusted via the headlamp aiming roller.

### Switching to high/low beam

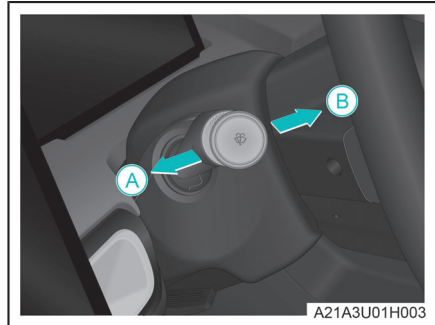

After the headlamp is on, push the light/wiper control lever in the direction of arrow A to switch the headlamp to the high beam, and pull back the light/wiper control lever in the direction of arrow B to turn off the high beam.

Repeatedly pull the light/wiper control lever in the direction of arrow B and reset it to switch between the high beam and the low beam in order to remind other traffic participants (such as when meeting, overtaking or crossing an intersection).

### Turn signal lamp

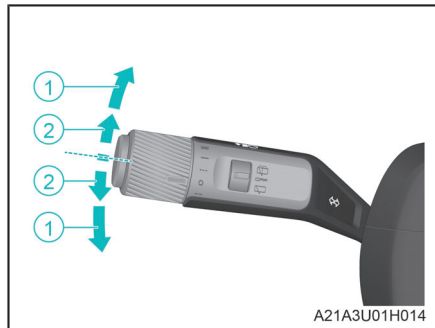



Turn signal: Move the light/wiper control lever to ① position to make the corresponding side turn signal lamp flash continuously.

Lane change signal: Move the light/wiper control lever to ② position slightly and release it. Then the light/wiper control lever will return to the original position automatically, and the corresponding side turn signal lamp will flash 3 times.





## Turning on fog lamp

After the headlamps are on, touch the  button on the center console display to enter the quick control interface and then touch the rear fog lamp button to turn on the rear fog lamp. The rear fog lamp indicator lamp  on the instrument will come on.

## Turning on position lamp

If the automatic headlamp function is activated, the position lamp will be turned on or off automatically according to the ambient light.

Switch on the vehicle power supply, touch the  button on the center console display to enter the quick control interface and then touch the position lamp button to turn on the position lamp. The position lamp indicator lamp  on the instrument will come on.

### NOTE

- ◆ When the vehicle is started and the headlamp is not on, only the rear position lamp is turned on.

## Daytime running lamp

The daytime running lamp is turned on automatically when the vehicle is started and the headlamp is not on, to enable other traffic participants to detect your vehicle easily.

### WARNING

- ◆ Please use the light reasonably according to the road condition and the driving environment.
- ◆ The high beam may cause dazzling to drivers of oncoming vehicles at close range, which may easily cause accidents. Therefore, please use the high beam reasonably.
- ◆ When the vehicle is passing a sharp turn, hill, arch bridge, crosswalk or intersection without traffic lights, the high beam and low beam should be turned on alternately for warning.

### NOTE



- ◆ In some humid conditions (such as high air humidity, vehicle washing, etc.), the inside of the lamp may be covered with a layer of fog or even a small amount of water drops. This is caused by water mist that is generated due to that humid air enters the lamp through the vent hole, and the temperature of the lamp lens is relatively low, which is similar to the fogging of vehicle windows on rainy days. This is a normal physical phenomenon and will not affect the function and service life of the lamp.
- ◆ When the vehicle is in a dry environment or the lamps are turned on, the water vapor will gradually evaporate, and there may be residues only at the corners of the lamps, but the fogging phenomenon may appear repeatedly.
- ◆ If there are a lot of water drops or accumulated water in the lamps, please contact the GAC AION sales store for inspection and repair.
- ◆ If you forget to turn off the position lamps, they will automatically go out after the vehicle power supply is turned off for a while or the vehicle enters the anti-theft state, in order to save the battery power.
- ◆ If one turn signal lamp fails, the other turn signal lamp on the corresponding side and the corresponding turn signal indicator lamp on the instrument will flash at a higher frequency.
- ◆ After a collision, all turn signal lamps and turn signal indicator lamps will flash at the same time.
- ◆ The windshield should be replaced together with the rain-light sensor.
- ◆ In a haze environment, the lights will not be turned on automatically and need to be turned on manually.



## Intelligent High Beam Control (IHBC)\*

After the IHBC is turned on, the vehicle automatically switches between high and low beams according to the driving environment.

### Using the IHBC

1. Turn on the IHBC on the center console display.
2. Turn on the automatic headlamp function on the center console display.
3. When the driving environment is dark, after the headlamps are automatically turned on, the IHBC is activated and the IHBC indicator lamp  on the instrument comes on.
4. After the IHBC is activated, the vehicle detects the driving environment and automatically switches between high and low beams. When it automatically switches to high beam, the indicator lamp  on the instrument comes on.

### System limitations

Under certain conditions including but not limited to the following, the IHBC may not work normally:

- ◇ The vehicle travels at a low speed.
- ◇ The fog lights are on.
- ◇ The wiper is operating at high speed for a period of time.
- ◇ The driving environment is bright.
- ◇ The driver drives the vehicle aggressively. (Such as emergency braking, sharp turns, etc.)
- ◇ The turn signal lamp is on.
- ◇ The windshield surface in front of the smart front camera is covered with foreign objects.

- ◇ When driving on dimly lit streets, there are highly reflective objects ahead.
- ◇ When driving in an environment with insufficient lighting, there are pedestrians or bicycles ahead.
- ◇ The lights of oncoming vehicles are blocked (such as by crash barriers, high central guardrails, green belts, etc.).
- ◇ When following the preceding vehicle, the brightness of the taillights of the preceding vehicle is dim or does not meet national standards.
- ◇ When the vehicle is driving on sharp turns/mountain roads/rugged roads.
- ◇ When the vehicle is driving on slopes or bumpy roads.
- ◇ When the vehicle is driving in bad weather such as heavy rain, snow, fog, etc.
- ◇ When the system is faulty.

### WARNING

- ◆ The IHBC is only a driving assistance function that helps you use the best lighting method when conditions are suitable.
- ◆ The driver is always responsible for manually switching between high beam and low beam when traffic and environmental conditions require it.

### CAUTION

- ◆ The IHBC may not correctly recognize all driving environments and may not work properly in some environments.
- ◆ If the smart front camera is blocked by dirt, stickers, ice, snow, etc., the IHBC may become unavailable.

**i CAUTION (Cont'd)**

- ◆ Changes to the lighting system of the vehicle (such as modifying the headlamps) may also cause the IHBC to degrade or become unavailable.

**i NOTE**

- ◆ When you come across oncoming non-motorized vehicles such as bicycles or electric bicycles, the IHBC should be turned off in time to prevent dazzling the others.
- ◆ The flashing function of high beam and high beam can be manually turned on or off at any time.
- ◆ Turning off the automatic headlamp function will deactivate the IHBC.
- ◆ Manually turning on the flashing function of the high beam or low beam will also deactivate the IHBC.



## Wiper control

### Operation of front wiper

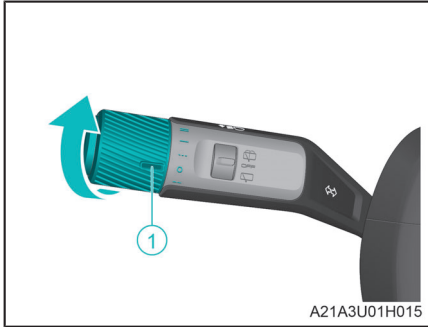

Turn the wiper control knob up or down from the position, so that the front wiper position icons are aligned with the wiper control knob position reference icons ① in turn, and the front wiper mode can be selected. The specific control is as follows:

- ◇ : The front wiper operates at a high speed.
- ◇ : The front wiper operates at a low speed.
- ◇ : The front wiper operates intermittently.
- ◇ : The front wiper is turned off.
- ◇ : Manual wiping. Set the wiper control lever to this position and hold it to achieve continuous operation of the front wiper. After being released, the wiper control lever returns to position, and the front wiper stops.

### Front windshield washing

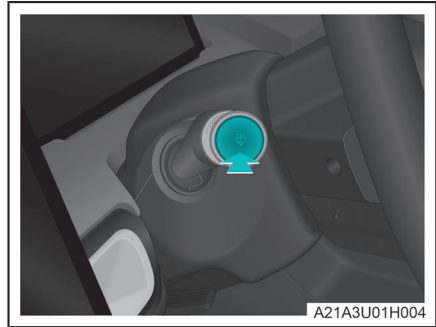

Press the front wiper washer button to have the front washer nozzle spray washer fluid. After the wiper control lever is released, the front washer nozzle stops spraying the washer fluid, the wiper operates several times, and then operates once after a period of time and stops.

### Wiping and washing operation of rear wiper

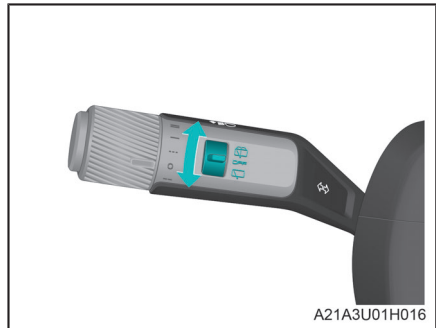

Toggle the rear wiper control switch up or down from the OFF position to select the rear wiper wiping method. The specific control is as follows:

- ◇ : Washing by the rear wiper. Toggle the rear wiper control switch to this position and hold it. The rear wiper nozzle will spray washing fluid while performing the wiping action. After being released, the rear wiper control switch returns to its original position.

- ◇ OFF: The wiping operation of the rear wiper is turned off.
- ◇ : The wiping operation of the rear wiper is turned on.

## Replacing wiper blades

1. Activate the wiper maintenance mode via the center console display. Then the front wiper blade will move to the highest position and then stop.

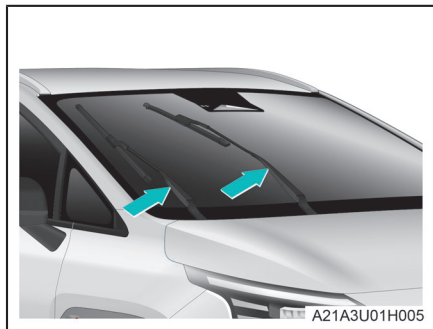

2. Pull up the wiper arm from the front windshield.

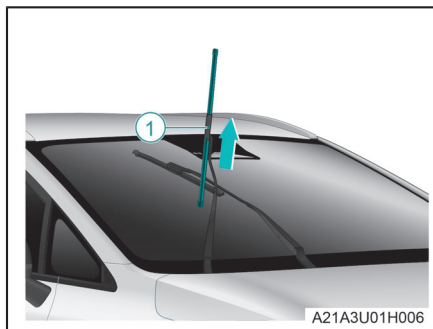

3. Press the wiper blade lock button , and remove the wiper blade in the direction of the arrow.
4. Install the wiper blade in reverse steps.
5. Gently put the wiper arm back onto the windshield.
6. Deactivate the wiper maintenance mode via the center console display. Then the front wiper blade will return to the original position automatically.

## Replacing rear wiper blades

1. Pull up the wiper arm from the rear windshield.



2. Pull the wiper blade in the direction of the arrow to remove it.
3. Install the wiper blade in reverse steps.
4. Gently put the wiper arm back onto the windshield.

### WARNING

- ◆ Check the wiper blades regularly. Check the rubber for cracks or local hardening. If these phenomena occur, the wiper blade should be replaced, otherwise, a stripe will be left after wiping or the windshield will not be wiped cleanly, affecting the driver's vision.

### CAUTION

- ◆ Do not open the hood when the front wiper arm is pulled up; otherwise the hood and the front wiper arm may be damaged.
- ◆ After the wiper blade is replaced, hold the wiper arm by hand and place it on the windshield slowly, so as to avoid damage to the windshield due to quick placement.
- ◆ After the wiper blade is removed, the wiper arm should be kept upright to avoid damage to the windshield due to fall of wiper arm.



### NOTE

- ◆ In cold days in winter or in hot days in summer, the wiper maintenance mode may be activated, and the front wiper should be lifted up from the front windshield.
- ◆ The automatic wiping function can be activated or deactivated via the center console display. If the function is activated, the wiper will wipe automatically when the wiper control lever is set to --- position.
- ◆ When the liftgate is open, the wiping and washing functions of the rear wiper will be disabled.
- ◆ With the liftgate closed and the front wiper turned on, if you shift the gear to "R", the rear wiper will follow the action of the front wiper.



## Forward Collision Warning (FCW)\*

The FCW timely reminds the driver to take measures to ensure driving safety in case of a potential collision risk by detecting the relative distance and speed with the vehicle ahead in the same path through the MMW radar sensor installed on the front of the vehicle and the LDW ECU in combination with the driver's other operations (such as depressing the brake pedal or accelerator pedal).

### Activation and deactivation

When the vehicle is started, the FCW will be activated automatically.



The FCW may also be activated or deactivated manually through the center console display.

### Setting forward collision warning distance

After the FCW is on, "Far", "Medium" and "Near" settings may be achieved for the forward collision warning distance through the center console display.

### Alert mode

After the FCW is on, if there is a risk of front collision with the vehicle speed greater than 30km/h, the instrument will display a prompt image, accompanied by audible alarm.

- ◇ Distance warning
  - When the distance warning of the FCW is triggered, the FCW system status indicator lamp  on the instrument flashes, accompanied by a prompt image.
- ◇ Proximity warning
  - When the early warning of the FCW is triggered, the FCW status indicator lamp  on the instrument will flash, accompanied by the audible alarm and visual prompt.

- ◇ Brake jerk warning
  - When detecting a high risk of collision with the target preceding vehicle, the FCW will trigger the brake jerk warning to remind the driver to carry out emergency braking immediately.

### WARNING

- ◆ The FCW is subject to the limitations of laws of physics, and thus shall never be used for risky driving.
- ◆ The FCW is not always effective under all circumstances. The driver must always be ready to control the vehicle. When the FCW gives alert, the driver must apply the brake to reduce the vehicle speed or avoid obstacles according to traffic conditions.
- ◆ The FCW is only a warning system to remind the driver to avoid collisions. It cannot replace the driver in providing the corresponding active brake assistance when an early warning is issued, so the driver must always keep control of the vehicle and take full responsibility for the speed of the vehicle and the distance from other vehicles.

### NOTE

- ◆ The FCW alerts can be stopped by depressing the accelerator pedal or turning the steering wheel.
- ◆ In a complex driving environment (such as traveling on a circuitous road), the FCW may give a false alarm.



## Autonomous Emergency Braking (AEB)\*

The AEB applies brake in case of a collision risk by detecting the relative distance and speed with the vehicle ahead in the same path through the MMW radar sensor installed on the front of the vehicle and the LDW ECU in combination with the driver's other operations (such as depressing the brake pedal or accelerator pedal). When detecting a vehicle or obstacle ahead and a risk of collision, the AEB will give a brake jerk warning and apply the brake. If you do not take braking measures, the AEB will increase the braking force to avoid or mitigate the collision. After giving a brake jerk warning, the AEB may not avoid an accident if you do not take braking measures and run the vehicle at a high speed.

### Activation and deactivation

When the vehicle is started, the AEB will be activated automatically.

The AEB may also be activated or deactivated manually through the center console display.

The AEB must be switched off under the following conditions:

- ◇ The vehicle is towed.
- ◇ The vehicle is on a chassis dynamometer. (such as during annual inspection)
- ◇ There is a radar sensor fault indication on the instrument.

### System limitations

Under certain conditions including but not limited to the following, the AEB may not work:

- ◇ The vehicle passes an extremely tight turn.
- ◇ The accelerator pedal is depressed quickly.
- ◇ The gear is not shifted to "D".
- ◇ The driver's seat belt is not fastened.
- ◇ The radar sensors are dirty or covered.
- ◇ The vehicle runs in a snowy or heavily rainy day.
- ◇ A narrow vehicle (such as a motorcycle) is traveling ahead.
- ◇ The vehicle meets a crossing approaching vehicle at a crossroad, etc.
- ◇ There is a stationary obstacle (such as a broken-down vehicle) in front.
- ◇ There is an oncoming vehicle.
- ◇ There is an oncoming or road-crossing animal.
- ◇ The detection performance is degraded due to interference by environmental factors (such as electromagnetic interference).

The AEB may not always be able to clearly identify objects and complex traffic conditions. In these cases, the AEB may:

- ◇ Issue a warning or apply braking when unnecessary.
- ◇ Fail to issue any warning or apply braking when necessary.





## WARNING

- ◆ The AEB can improve the driving safety, but it is still subject to the limitations of laws of kinematics, and thus shall never be used for risky driving. The driver must always be ready to apply the brake to reduce the vehicle speed or avoid obstacles.
- ◆ The braking effect that can be realized by the AEB to reduce injuries due to collision is limited and it cannot work autonomously to prevent vehicle accidents or personal injuries. Therefore, when the AEB is working, the driver is still required to apply braking when necessary
- ◆ When the AEB is activated, the driver shall keep controlling the vehicle during driving, and shall take full responsibility for the vehicle speed and the distance to other vehicles.
- ◆ The AEB is only effective to vehicles/ pedestrians detected by the radar sensor to mitigate injuries due to collision, and thus, it may respond after a certain delay. The driver shall apply the brake if necessary instead of waiting for the AEB to act.
- ◆ As the AEB is only a driver assistance system, the driver shall be fully responsible for keeping a proper distance from the vehicle ahead, controlling the speed and braking in time. The driver must always be ready for braking or steering.
- ◆ During AEB' s intervention in braking, the AEB can be stopped by depressing the accelerator pedal or turning the steering wheel.

## NOTE

- ◆ When the AEB is activated, the vehicle will be braked, and the foot may feel hard or vibration from the brake pedal, which is normal.
- ◆ In a complex driving environment (such as traveling on a circuitous road), AEB may intervene in braking.
- ◆ When the AEB is negatively affected by the environmental factors (for example, electromagnetic interference or the target itself), the detection function will be interfered and the AEB performance will be degraded.



## Cruise Control System (CCS)\*

The CCS allows the vehicle to run at the set cruising speed without depressing the accelerator pedal.

### Description of CCS buttons

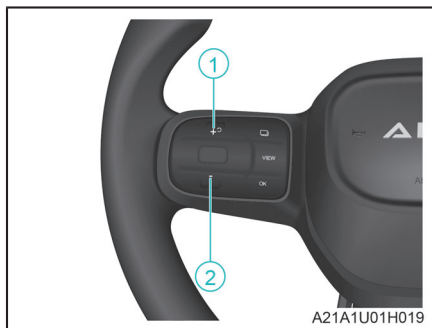



- ① Cruise control resumption/acceleration button
- ② Cruise control deceleration button

### Activating CCS

1. Set the gear to "D", control and keep the vehicle speed higher than 40 km/h.
2. Move the column shifter in the "D" gear direction twice. Then the green CCS indicator lamp  on the instrument will come on. After the accelerator pedal is released, the vehicle will cruise at the current speed.

### Increasing cruising speed

Press the  button on the steering wheel to increase the cruising speed.

Press and hold the  button on the steering wheel to increase the cruising speed continuously.

### Decreasing cruising speed

Press the  button on the steering wheel to reduce the cruising speed.

Press and hold the  button on the steering wheel to reduce the cruising speed continuously.

### Canceling cruise control

When the vehicle is in cruise control mode (green CCS indicator lamp  is on), depress the brake pedal or move the the column shifter in the "R" gear direction once to exit the cruise control.

### WARNING

- ◆ When driving on high-traffic roads, slopes, multi-curve roads or wet and slippery roads, do not use the cruise control for fear of accidents.
- ◆ Set speed and distance from the preceding vehicle must be adapted to the current traffic conditions. The CCS is only a driver assistance system and should be used provided that safety has been guaranteed.
- ◆ After exiting the cruise control mode, deactivate the CCS in time.

### **i** NOTE

- ◆ When the cruising speed is reduced to 40km/h, the cruising speed can no longer be reduced via the button on the steering wheel.
- ◆ When the accelerator pedal is depressed for overtaking as needed, the vehicle will temporarily exit the cruise control mode and the power output will be controlled by the accelerator pedal. After the accelerator pedal is released, the vehicle will resume the cruise control. During overtaking, please pay attention to the driving environment and keep a safety distance.
- ◆ When the cruise control is deactivated, if the vehicle speed is greater than 40km/h, the cruise control can be resumed by pressing the button on the steering wheel, to reach the last set cruising speed. The cruise control cannot be resumed if the vehicle speed is lower than 40km/h.

## Adaptive Cruise Control (ACC)\*

The ACC applies the millimeter wave radar installed on the front of the vehicle and the intelligent front camera on the front windshield to detect the relative distance and speed between your vehicle and the preceding vehicle on the same path, to control your vehicle to follow the preceding vehicle automatically.

- ◇ When no preceding vehicle is present, the ACC will control your vehicle to cruise at the set target speed.
- ◇ When a preceding vehicle is present, the system will automatically control your vehicle to cruise according to your vehiclespeed, the preceding vehicle speed and the set safety distance.

### Description of ACC buttons

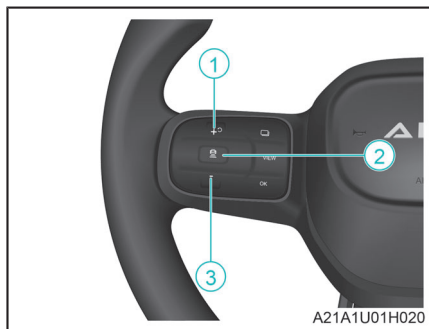

- ① Cruise control resumption/acceleration button
- ② ACC distance control button
- ③ Cruise control deceleration button

### ACC display interface on instrument

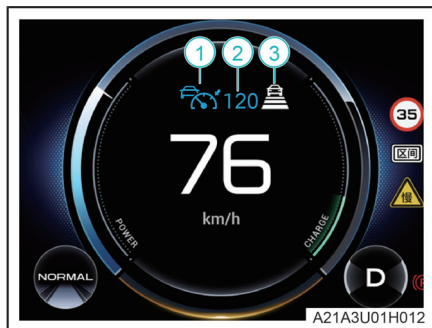

#### ① ACC indicator lamp

- With the ACC in ready state, when there is no target vehicle ahead, the indicator lamp comes on; when a target vehicle is detected, the indicator lamp comes on, accompanied by an alert.
- With the ACC activated, when there is no target vehicle ahead, the indicator lamp comes on; when a target vehicle is detected, the indicator lamp comes on.

#### ② Set cruising speed

#### ③ Set following distance

### Activating ACC

With the gear in “D”, move the column shifter quickly in the “D” gear direction once. Then the corresponding indicator lamp on the instrument turns green, and the vehicle enters the ACC mode. At this time, if the vehicle speed is higher than 15km/h, the current speed will be set as the cruising speed; if the vehicle speed is lower than 15km/h, the cruising speed will be set at 15km/h.

### Increasing cruising speed

Press the button on the steering wheel to increase the cruising speed.

Press and hold the button on the steering wheel to increase the cruising speed continuously.

### Decreasing cruising speed

Press the button on the steering wheel to reduce the cruising speed.

Press and hold the button on the steering wheel to reduce the cruising speed continuously.

### Adjusting the following distance for ACC

Press the button on the steering wheel to adjust the following distance, which is displayed on the instrument. The distance is farthest when set to the 4th gear.

### Resuming ACC after following stop

In ACC mode, your vehicle will stop when the preceding vehicle stops. Depending on the stop time of the preceding vehicle, when the preceding vehicle drives off, the ACC of your vehicle will be in the following 2 states:

- ◇ In case of short-time stop of the preceding vehicle, the blue indicator lamp will come on. In that case, if the preceding vehicle drives off, the ACC of your vehicle will be resumed automatically.
- ◇ In case of long-time stop of the preceding vehicle, the indicator lamp will come on. In that case, if the preceding vehicle drives off, the ACC of your vehicle will be resumed by depressing the accelerator pedal or pressing the button on the steering wheel.

### Canceling/resuming ACC

When the vehicle is in ACC mode, the ACC will be canceled if the brake pedal is depressed or the column shifter is moved in the “R” gear direction once. At that time, pressing the button on the steering wheel can resume the ACC.



## System limitations

The ACC is subject to limitation of physical laws, and thus in some driving environments, the driver may find that the vehicle is not controlled as expected after the reaction of the ACC, therefore, the driver must always be ready to control the vehicle. The following conditions will affect functions of the radar sensor, so the driver must be particularly alert under these conditions:

- ◇ Decelerating to stop. If the preceding vehicle is stopped by emergency braking, the ACC will also decelerate your vehicle or send a take-over request. The driver should actively intervene by braking according to the take-over request to stop the vehicle completely.

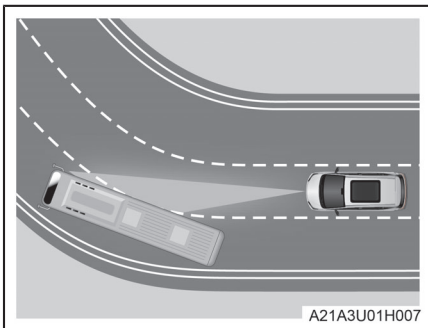

- ◇ Driving through a curve. During driving through a curve, the radar sensor may fail to capture the vehicle ahead, or may respond to vehicles in adjacent lanes. In this case, the ACC may brake the vehicle, reduce the vehicle speed, or make no response to the vehicle ahead. At that time, step on the brake pedal or manually cancel the ACC.

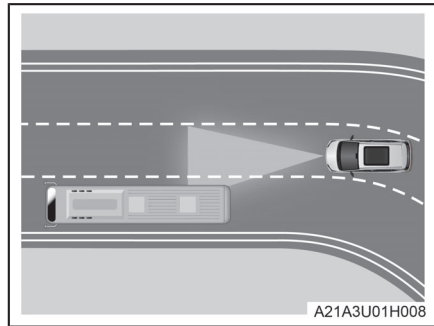

- ◇ Driving out of a curve. During driving out of a long curve, as the ACC will calculate the lane in advance, the radar may respond to the vehicles in adjacent lanes and apply the brake of your vehicle. This braking process can be interrupted by depressing the accelerator pedal.

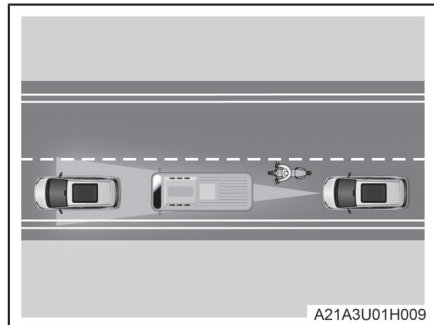

- ◇ Narrow vehicles and Z-shaped traffic in front. The narrow vehicles and Z-shaped traffic in front can be detected by the radar sensor only when they enter the detection range of the radar sensor. That is to say, the system cannot identify vehicles out of the detection range of the sensor. The ACC may be unable to identify narrow vehicles such as motorcycles, and has a risk of failing to accurately identify the distance from modified vehicles and vehicles involving non-standard transportation in front, so it is not recommended to take such vehicles as the target vehicle ahead.



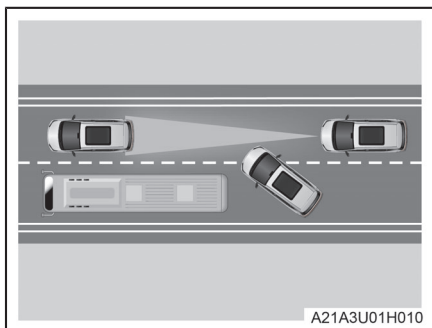

- ◇ Lane change of other vehicles. When a vehicle in the adjacent lane goes into the your lane, if it does not enter the detection range, it could not be detected by the radar sensor, thus resulting in a response lag of the ACC.

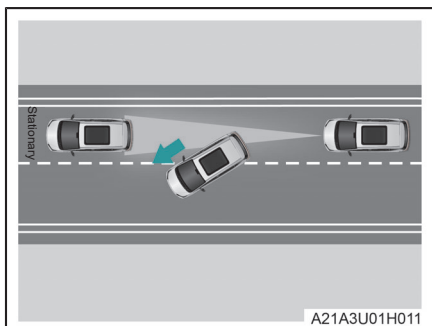

- ◇ If the target vehicle in front is driven out suddenly and a stationary vehicle appears at close range, the radar sensor and brake actuator will incur a response lag, causing delayed braking response.

- ◇ Influencing factors that may deteriorate the sensor function:

- Driving under harsh operating conditions such as rainstorm, mist, ice, snow or sludge.
- Driving in cold areas. (frosting or fogging of front windshield due to temperature difference or frost will block the camera)

Under the above condition, after the radar sensor is affected, the warning message "The ACC is currently out of service", "Please check the FCW" or "Please check the AEB" will appear on the instrument. At this time, the ACC, FCW and AEB do not work.

- ◇ Brake overheating. If the brake is overheated due to emergency braking or during traveling down a steep slope, the ACC will be deactivated automatically and temporarily. Meanwhile, the following text message will appear on the instrument: "The ACC is currently out of service". In that case, the ACC can no longer be activated, and it can be activated again only when the brake temperature drops to a reasonable value.
- ◇ The ACC should not be used in cities with traffic jams and poor visibility (night/backlighting/rain/snow/dense fog, etc.). The ACC may not take braking measures in face of people, animals, narrow vehicles such as bicycles, motorcycles or electromobiles, drop frame trailers, approaching or stationary vehicles, and low-speed or stationary trucks/small pickup trucks, so the driver should be particularly alert and always be ready to take over the vehicle.

 **WARNING**

- ◆ The ACC is not a safety system, obstacle detector, collision alarm or anti-collision system, but a comfort system, so the driver must always keep control of the vehicle and take full responsibility for the vehicle.
- ◆ The ACC must be used cautiously according to the visibility, weather conditions, road and traffic conditions at the time. The driver must always keep control of the vehicle and take full responsibility for the speed of the vehicle and the distance from other vehicles.
- ◆ The ACC cannot substitute for driver's attention and judgment. The driver should always be responsible for ensuring that the vehicle travels safely at an appropriate speed and maintains an appropriate distance from other vehicles.
- ◆ The ACC cannot address all driving scenarios and traffic, weather and road conditions.
- ◆ The ACC is only a driver assist system, and cannot replace your attention and judgment. It is your responsibility to maintain a safe distance and speed, and you must be ready to intervene if the ACC fails to maintain a proper speed or distance from the vehicle ahead.

 **WARNING (Cont'd)**

- ◆ The take-over reminder of the ACC only warns the driver of vehicles detected by its radar sensor and camera, so the ACC may not send an alarm, or may send an alarm after a certain delay. Therefore, the driver shall apply the brake in time as required instead of waiting for the alarm.
- ◆ Do not use the ACC under conditions such as urban driving, traffic jams, multi-curve roads and poor road conditions (e.g. ice, fog, gravel, heavy rain, and phenomena prone to slipping).
- ◆ The ACC is not a collision avoidance system. If your vehicle is getting closer and closer to the vehicle ahead at a speed higher than that of the vehicle ahead and the braking effect of the ACC is unable to stop the vehicle safely before a collision with the vehicle ahead, the driver must depress the brake pedal to reduce the vehicle speed.
- ◆ Do not activate the ACC during driving in roadless areas or on earth roads. The ACC can only be activated on flat roads paved with pitch, cement, etc.
- ◆ The ACC will make no or limited response to the followings:
  - Large speed difference with the vehicle ahead.
  - Driving in different lanes, lane changes or driving on curves with small radius.
  - Pedestrians, animals, bicycles, stationary vehicles, unexpected obstacles, etc.
  - Approaching stationary obstacles such as broken-down vehicles.
  - A vehicle in the same lane approaching your vehicle.



 **WARNING (Cont'd)**

- Complex traffic conditions.
- Oncoming traffic or cross traffic.
- Low trailers or trucks, and vehicles with irregular or non-standard characteristics.
- ◆ Metal objects such as tracks, metal plates, roadside obstacles such as concrete walls, dense grass and fences, as well as high voltage bridges, toll booths and tunnels can interfere with the normal operation of the radar sensor and cause the ACC not to be triggered or to be mistakenly triggered. The driver needs to be alert and ready to take over the vehicle at all times.
- ◆ A vehicle in an adjacent lane rapidly moving in the lateral direction or traveling in close proximity to your vehicle may cause an incorrect determination of a target by the ACC, resulting in the vehicle braking and requesting the driver to take over it.
- ◆ Be sure to notice traffic conditions and respond accordingly. Do not wait for the system to identify the target or apply the brake, but apply the brake as needed.
- ◆ The ACC may not respond to people, animals and vehicles crossing or approaching the vehicle in the same lane.
- ◆ When driving through crossroads, speed bumps, steep roads and zebra crossings, or at changing lanes, highway access, ramps or construction sections, it is required to exit the ACC for manual driving, lest the vehicle should be automatically accelerated to the set speed, causing traffic accidents.

 **WARNING (Cont'd)**

- ◆ The ACC can automatically drive the vehicle out after a short stop or confirmation from the driver (control of buttons or accelerator pedal). During this period, the driver must ensure that there are no obstacles or other traffic participants such as pedestrians/bicycles ahead of the vehicle.
- ◆ The ACC can not identify a vehicle ahead that is already stationary or travels very slow (close to stopping), but it can stop with the moving vehicle that has been identified and selected as a target by the ACC. During following stop, the driver still needs to be ready to take over the vehicles at all times to guard against accidents.
- ◆ The ACC can only achieve limited braking force, not emergency braking.
- ◆ When the vehicle is ready for driving and the gear is set to “D”, after the ACC is activated, the stationary vehicle will enter the driving state, so it is necessary to operate carefully.
- ◆ After the vehicle enters the ACC control state from the stationary state, the vehicle speed may increase suddenly. In this case, please ensure the safety around the vehicle to avoid accidents.



### CAUTION

- ◆ If the ACC fault indicator  comes on, it indicates that the ACC is faulty. It is recommended to contact the GAC AION sales store for inspection and repair.
- ◆ Do not bump the radar sensor. If the sensor is misaligned due to bumps, it will deteriorate the system performance and even cause the system shutdown even through maintenance and correction are made.
- ◆ If the surface of the radar sensor or camera is dirty or covered by rain, ice, snow, sludge, etc., the ACC may not function, and the instrument will display the prompt message reading "Please check the ACC". After the dirt is cleaned off the sensor surface, the ACC will return to normal.
- ◆ Do not spray the front bumper with vehicle paint without permission, otherwise the performance of the frontal radar may be degraded.
- ◆ If the ACC fails to function properly, stop using it, and contact the GAC AION sales store for inspection in time.

### NOTE

- ◆ The set cruising speed will be deleted after the vehicle is powered off.
- ◆ Prevent placing your foot on the accelerator pedal when not required; otherwise, the ACC cannot function for braking, as the depressing of accelerator pedal will cause excessive control of vehicle speed and distance.

### NOTE (Cont'd)

- ◆ When the ACC is activated, the ACC status displayed on the instrument may be overwritten by other functions (for example, during a call).
- ◆ When the ACC brakes the vehicle automatically after activation, there will be a sound different from manual braking sound or the brake pedal will be depressed automatically, which is normal. Such sound and pedal action are caused by the operation of the brake system, so there is no need to worry.
 

The accelerator pedal can be depressed when required to increase the vehicle speed. After the accelerator pedal is released, the ACC will readjust the vehicle speed to the previously set cruising speed.
- ◆ If the vehicle enters a tunnel, the radar and camera may be temporarily inactive, and the ACC may be turned off temporarily.
 

In addition to depressing the brake pedal and moving the column shifter in the "R" gear direction once to cancel the ACC, the following operations can also cancel the ACC:

  - Operating the EPB button.
  - Opening the driver's door.
  - Unfastening the driver's seat belt.
  - Shifting the column shifter into any gear other than "D".



## Integrated Cruise Assist (ICA)\*

The ICA detects the relative distance and speed between your vehicle and the preceding vehicle on the same path as well as the lane markings according to the signals from the MMW radar installed on the front bumper and the smart front camera installed on the front windshield. The ICA can automatically adjust the distance from the vehicle ahead during cruise control and keep the vehicle traveling in the middle of the lane.

### ICA display interface on instrument

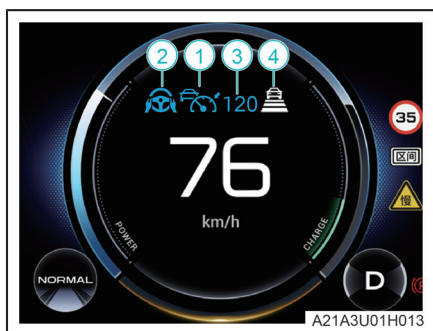

#### ① Longitudinal control

- When the vehicle is ready for cruise control, if there is no vehicle ahead, the indicator lamp comes on; if there is a vehicle ahead, the indicator lamp comes on.
- When the vehicle is in cruise control, if there is no vehicle ahead, the indicator lamp comes on; if there is a vehicle ahead, the indicator lamp comes on.

#### ② Lateral control and driver's hands off steering wheel

- When the ICA is ready, the indicator lamp comes on; when ICA lateral control is activated, the blue indicator lamp comes on; when it is detected that the driver's hands are off the steering wheel, the hands-off warning lamp flashes.

#### ③ Set cruising speed

#### ④ Set following distance

### Activating ICA

With the gear in "D", move the column shifter quickly in the "D" gear direction twice to activate the ICA.

### Canceling ICA

When the vehicle is in ACC mode, the ACC will be deactivated if the brake pedal is depressed or the column shifter is moved in the "R" gear direction once.

### Lateral control

When the ICA is activated, it performs lateral control of the vehicle by identifying the effective lane markings on both sides, so that the vehicle can keep traveling in the center of the lane. The lateral control will be suppressed under the following conditions:

- ◇ High curvature or missing of lane markings.
- ◇ Violent driving.
- ◇ Turn signal lamp on.
- ◇ Hazard warning lamp on.
- ◇ Steering wheel turned by the driver.
- ◇ Take-over reminder from the system.
- ◇ ACC deactivated.

### Longitudinal control

Refer to Adaptive Cruise Control (ACC) for ICA longitudinal control.

### Take-over reminder

In the following cases, the ICA will issue a take-over reminder accompanied by a sound alert.

- ◇ When the ICA detects that the driver's hands are off the steering wheel for a long time.
- ◇ When the ICA requires the driver to intervene in braking. (The ICA can only use limited brake capacity of service brake system)

Please take over the vehicle immediately after the vehicle sends out the take-over reminder.

### System limitations

The ICA has limitations and may incorrectly detect lane markings or fail to detect lane markings, or may incorrectly detect target vehicles or fail to detect target vehicles ahead. Even if enabled and activated, the ICA may be affected, malfunction or not function under the following conditions:

- ◇ Poor line of sight, such as snow, rain, fog or water spots.
- ◇ Dirty or foggy windshield, or obstruction in front of the windshield camera.
- ◇ Overtemperature around the camera due to direct sun exposure.
- ◇ Glare due to direct sunlight, light from oncoming traffic, reflected light from road water-logging, etc.
- ◇ Sudden changes in outdoor brightness, such as entering/exiting tunnels.
- ◇ Headlamp not turned on at night or when the lighting is dim in tunnels.
- ◇ No lane marking, or difficulty in distinguishing the lane marking color from the road color.
- ◇ Unclear, too thin, worn, blurred or dirt/snow-covered lane markings.
- ◇ Too wide or narrow lanes.
- ◇ Increase or decrease in lanes, or complicated routing of lane markings.
- ◇ More than two lane markings on the left and right sides of the vehicle.
- ◇ Marks or objects similar to lane markings on roads.



- ◇ Median strips or other objects casting shadows on lane markings.
- ◇ Short-time change of lane marking, such as ramp or highway exit.
- ◇ Driving on steep slopes or bumpy roads.
- ◇ Close distance from the preceding vehicle or lane markings blocked by the preceding vehicle.
- ◇ Severe shaking of the vehicle.

The lateral control assist performance of the ICA may be affected under the following conditions:

- ◇ The vehicle is overloaded.
- ◇ Abnormal tire pressure.
- ◇ Uneven road.
- ◇ Strong crosswinds.
- ◇ Vehicle control-related parts are modified by the driver.
- ◇ Vehicle control-related parts are replaced with non-genuine ones.
- ◇ Vehicle control-related parts are improperly assembled.

## WARNING

- ◆ The ICA only provides a driving assistance function and cannot address all road, traffic and weather conditions. The driver always takes full responsibility for driving, and shall always check the road conditions and actively control the vehicle.
- ◆ The driver must hold the steering wheel all the time to actively control the vehicle. When the ICA does not provide proper steering assist or appropriate headway, the driver shall intervene timely.
- ◆ Improper use of the ICA or negligence may lead to accidents, so the driver should always control the vehicle, and maintain an appropriate speed and headway to keep the vehicle traveling correctly in the lane, even if using the ICA.
- ◆ The ICA is not a collision avoidance system. When the system does not take proper control, the driver must intervene.
- ◆ Under conditions such as urban traffic, intersections, water-logged or snowy roads, adverse weather, mountain roads, rough roads and highway access, it is recommended not to use the ICA.
- ◆ The ICA is not always able to identify the lane markings, and in some cases may mistakenly identify or even not identify a lane marking, so the ICA may not generate lateral assist when needed, or may generate unnecessary lateral assist by mistake.



### WARNING (Cont'd)

- ◆ The ICA can only use limited capability of steering system, so it cannot cope with all driving conditions. The driver must keep his hands on the steering wheel all the time and drive with care. The driver must hold the steering wheel or reduce the vehicle speed appropriately on high-speed curves.
- ◆ The ICA cannot perform braking in face of pedestrians, animals, foreign objects, lowbed trailers or oncoming traffic.
- ◆ The ICA cannot address all traffic conditions. For example, the lateral assist may suddenly exit under conditions such as high curvature of lane marking before a sharp curve, and roads without lane markings. The driver must hold the steering wheel all the time to actively control the vehicle.
- ◆ The driver shall immediately hold the steering wheel immediately after receiving the take-over reminder. Do not panic or turn the steering wheel fiercely.

### CAUTION

- ◆ If the yellow indicator lamp  comes on, it indicates that the ICA is faulty. It is recommended to contact the GAC AION sales store for inspection.

### NOTE

- ◆ The ICA may misjudge the driver's hands lightly on the steering wheel as taking both hands off the steering wheel.
- ◆ If the ICA is inhibited for some reason, it will automatically restore when the working conditions are met.
- ◆ When judging that the ICA does not control the vehicle properly, the driver should hold the steering wheel firmly and control it properly, and the ICA function will be interrupted by the driver's operation.
- ◆ When the ICA controls the steering wheel for assistance, the driver can still turn the steering wheel to control the vehicle. When the driver feels an implausible torque applied to the steering wheel by the system, the driver may take over control of the vehicle at any time to drive it at will.
- ◆ In addition to depressing the brake pedal and moving the column shifter in the "R" gear direction once to cancel the ICA, the following operations can also cancel the ICA:
  - Depressing the accelerator pedal quickly.
  - Unfastening the driver's seat belt.
  - Pressing the hazard warning lamp switch.



## Lane Departure Warning (LDW)\*

The LDW detects the vehicle ahead and lane markings via the MMW radar installed in the front of the vehicle and the smart front camera installed on the front windshield, and gives an alarm or intervention when it detects signs of vehicle deviation.

### Activation and deactivation



The LDW can be turned on or off via the center console display.

### Selecting lane departure assist mode

After the LDW is turned on, the lane departure assist mode can be selected as “Steering”, “Warning” or “Steering and Warning” on the center console display.

- ◇ When “Steering” is selected, the system only intervenes in turning of steering wheel for corrective steering adjustment.
- ◇ When “Warning” is selected, the system only issues a warning.
- ◇ When “Steering and Warning” is selected, the system will not only issue a warning but also intervene in turning of the steering wheel for corrective steering adjustment.

### Lane departure warning/correction

After the LDW function is enabled, the indicator lamp  on the instrument will come on, and the LDW will enter the ready state. When the following conditions are met, the LDW will be activated and the green indicator lamp  will come on.

- ◇ The vehicle speed is higher than 60km/h.
- ◇ The system detects valid lane marking on at least one side.

When the LDW is activated, if the vehicle deviates from the lane, the system will send out an alert or make corrective steering adjustment according to the set lane departure assist mode. When the LDW is activated, if the vehicle deviates from the lane under the following conditions, the system will not give an alarm or make corrective steering adjustment:

- ◇ The accelerator pedal is quickly depressed for acceleration.
- ◇ The brake pedal is slammed for deceleration.
- ◇ Corresponding turn signal lamp is turned on.
- ◇ Hazard warning lamp on.
- ◇ The steering wheel is turned quickly;
- ◇ The time interval from the last alarm is short;
- ◇ The car is running on or across the lane marking continuously;
- ◇ The system alerts the driver to take over the steering wheel.

### Take-over reminder

When detecting that the driver's hands are off the steering wheel for a long time, the LDW will issue a take-over reminder. The instrument will display the prompt message reading “Please take over the steering wheel immediately” and the buzzer will beep. (The system may misjudge the driver's hands lightly on the steering wheel as taking both hands off the steering wheel.)

When the system sends out a take-over reminder, please take over the vehicle to ensure driving safety.

### Other prompts

When the instrument displays the prompt message reading “LDW is temporarily unavailable”, it indicates that the smart front camera on the front windshield fails. Generally, this is because the front windshield is dirty or the smart front camera is directly exposed to sunlight. The LDW will not be damaged due to this and needs not to be inspected.



When the instrument displays the prompt message reading “Please check the LDW” and the red LDW status indicator lamp  comes on, it indicates that there is a fault in the system. It is recommended to contact the GAC AION sales store for inspection.

### System limitations

The limitations include but are not limited to, the following situations where the system may become affected or inoperative:

- ◇ Poor line of sight, such as snow, rain, fog or water spots.
- ◇ Dirty or foggy front windshield, or obstruction in front of the smart front camera.
- ◇ Overtemperature around the smart front camera due to direct sunlight.
- ◇ Glare due to direct sunlight, light from oncoming traffic, reflected light from road water-logging, etc.
- ◇ Sudden changes in outdoor brightness, such as entering/exiting tunnels.
- ◇ Headlamp not turned on at night or when the lighting is dim in tunnels.
- ◇ No lane marking, or difficulty in distinguishing the lane marking color from the road color.
- ◇ Unclear, too thin, worn, blurred or dirt/snow-covered lane markings.
- ◇ Too wide or narrow lanes.
- ◇ Increase or decrease in lane markings, or complicated routing of lane markings.
- ◇ More than two lane markings on the left and right sides of the vehicle.
- ◇ Marks or objects similar to lane markings on roads.

- ◇ Median strips or other objects casting shadows on lane markings.
- ◇ Short-time change of lane marking, such as ramp or highway exit.
- ◇ Driving on steep slopes or bumpy roads.
- ◇ Close distance from the preceding vehicle or lane markings blocked by the preceding vehicle.
- ◇ Severe shaking of the vehicle.

Under the following conditions, the performance of the system may be affected while it is intervening in turning of steering wheel for corrective steering adjustment:

- ◇ The vehicle is overloaded.
- ◇ Abnormal tire pressure.
- ◇ Uneven road.
- ◇ Strong crosswinds.
- ◇ Vehicle control-related parts are modified by the driver.
- ◇ Vehicle control-related parts are replaced with non-genuine parts.
- ◇ Vehicle control-related parts are improperly assembled.



 **WARNING**

- ◆ The LDW is just a driver assistance system and cannot actively control the vehicle to change lanes or keep it in the lane. The driver must always check the road conditions, hold the steering wheel and actively control the vehicle.
- ◆ Improper use of the LDW or negligence may cause an accident. Do not rely on the LDW completely or drive the vehicle at risk with the aid of the system.
- ◆ The LDW is not always able to identify a lane marking and a lane edge. The system may mistakenly identify or even don't identify a lane marking or a lane edge due to bad weather, poor night lighting, water or snow on road, damaged or blurry lane markings, or shade on roads. Therefore, the driver should concentrate on observing road and traffic conditions and drive carefully.
- ◆ Protect the smart front camera against strong impact, moisture or heat; and never remove and refit any part without authorization. Do not place reflective objects on the instrument panel, which are not only easy to dazzle the driver but also may reflect the light to the detection range of the smart front camera, affecting the normal operation of the system.

 **WARNING (Cont'd)**

- ◆ The system can only adjust limited steering angle, so it can't promise that the car will be driven back into the lane under any circumstances.
- ◆ The sound inside or the noise outside may prevent you from hearing the warning beep, so you may not notice the warning issued from the LDW under any circumstances.
- ◆ When detecting that the driver's hands are off the steering wheel for a long time or the vehicle unintentionally deviates from the lane, the LDW will give a warning or intervene in turning of steering wheel for corrective steering adjustment.
- ◆ When the LDW intervenes in turning of the steering wheel for corrective steering adjustment, the driver can still turn the steering wheel to control the vehicle. When the driver feels an implausible torque applied to the steering wheel by the system, the driver may take over control of the vehicle at any time to drive it at will.





### CAUTION

- ◆ Do not color or coat the front windshield with any material not meeting the corresponding specifications. Any additional objects that negatively affect the sight of the smart front camera may lead to improper operation of the system.
- ◆ The LDW with curb recognition function uses signals from MMW radar sensor. Avoid impact or modification to the bumper or vehicle body; otherwise the LDW may operate abnormally.

### NOTE

- ◆ When the system only detects valid lane markings on one side, the function can be activated, but warning or corrective steering adjustment will be carried out only on that side.

## Lane Keeping Assist (LKA)\*

The LKA detects the lane markings in real time through the smart front camera on the front windshield, and when the driver is distracted and deviates from the lane, it corrects the traveling direction of the vehicle by controlling the EPS to assist the driver to keep the vehicle in the lane.

### Activation and deactivation

The LKA can be turned on or off via the center console display.

### Alert mode

When the vehicle speed exceeds 60km/h, if the driver is distracted and deviates from the lane, the system will actively control the steering and sends out a reminder.

### System limitations

Due to unavoidable environmental factors and conditions, the system may also give an alarm when the alarm conditions are not met. Conditions in which a false alarm may be issued:

- ◇ Poor line of sight caused by snow, rain, fog, water spots, etc.
- ◇ Dirty or foggy windshield, or obstruction in front of the smart front camera;
- ◇ Overtemperature around the camera due to direct sun exposure.
- ◇ Glare due to direct sunlight, light from oncoming traffic, reflected light from road water-logging, etc.
- ◇ Sudden changes in outdoor brightness, such as entering/exiting tunnels;
- ◇ Headlamps not turned on at night or when the light is low in tunnels;
- ◇ No lane marking, or difficulty in distinguishing the lane marking color from the road color;



- ◇ Unclear, too thin, worn, blurred or dirt/snow-covered lane markings.
- ◇ Too wide or narrow lanes.
- ◇ Increase or decrease in lanes, or complicated routing of lane markings.
- ◇ More than two lane markings on the left and right sides of the vehicle.
- ◇ Marks or objects similar to lane markings on roads.
- ◇ Median strips or other objects casting shadows on lane markings.
- ◇ Short-time change of lane marking, such as ramp or highway exit.
- ◇ Driving on steep slopes or bumpy roads.
- ◇ Close distance from the preceding vehicle or lane markings blocked by the preceding vehicle.
- ◇ Severe shaking of the vehicle.
- ◇ Passing by road guardrails, highway concrete walls, trees, shrubs, etc.
- ◇ The vehicle passes over speed bumps or potholes.
- ◇ The vehicle passes through dense buildings.
- ◇ Vehicle control-related parts are improperly assembled.

## WARNING

- ◆ The LKA is only a driver assistance system, and cannot replace the driver's monitoring on the traffic conditions, and the driver should always be alert to the surrounding environment.
- ◆ The driver shall always hold the steering wheel to actively control the vehicle.
- ◆ When the road environment cannot meet the operating conditions of the LDW, it may not work properly.

## NOTE

- ◆ When the system intervenes in turning of the steering wheel for assistance, the driver can still turn the steering wheel to control the vehicle. When the driver feels an implausible torque applied to the steering wheel by the system, the driver may take over control of the vehicle at any time to drive it at will.

Under the following conditions, the performance of the system may be affected while it is intervening in turning of steering wheel for corrective steering adjustment:

- ◇ The vehicle is overloaded.
- ◇ Abnormal tire pressure.
- ◇ Uneven road.
- ◇ Strong crosswinds.
- ◇ Vehicle control-related parts are modified by the driver.
- ◇ Vehicle control-related parts are replaced with non-genuine parts.



## Driving in fog

In case of driving in fog, please read and observe the following.

### DANGER

- ◆ Before driving, check the lighting system, turn on the fog lamps, position lamps and low beams to improve visibility to avoid traffic accidents.
- ◆ In heavy fog, try to avoid driving a vehicle to avoid traffic accidents.
- ◆ When driving in fog, do not sharply step on or quickly release the accelerator pedal, and do not brake the vehicle or turn the steering wheel suddenly. If it is necessary to reduce the vehicle speed, first slowly release the accelerator pedal, and then lightly step on the brake pedal several times to control the vehicle speed and prevent rear-end collisions.
- ◆ Do not turn on high beams when driving in fog.

### WARNING

- ◆ When driving in fog, slow down and sound the horn if necessary to alert other pedestrians and vehicles. If any horns of other vehicles are heard, it is also necessary to respond by sounding the horn immediately, indicating the location of your vehicle.
- ◆ When driving in fog, try to drive the vehicle in the middle of the road to avoid colliding with vehicles temporarily parked on the side of the road waiting for the fog to disperse.

### NOTE

- ◆ When driving in fog, please control the vehicle speed and obey the relevant laws and regulations.

## Driving in rain

In case of driving in rain, please read and observe the following.

### DANGER

- ◆ When driving in rain, do not sharply step on or quickly release the accelerator pedal, and do not brake the vehicle or turn the steering wheel suddenly. If it is necessary to reduce the vehicle speed, first slowly release the accelerator pedal, and then lightly step on the brake pedal several times to control the vehicle speed and prevent rear-end collisions.

### WARNING

- ◆ When it starts to rain and the road becomes slippery, drive the vehicle at a reduced speed.
- ◆ When driving on cloudy or heavily rainy and foggy days with poor visibility, turn on the fog lamps and low beams in time.
- ◆ When it rains, the visibility is reduced, it is liable to fog up on the windows and the road is slippery, so drive the vehicle with caution.
- ◆ When it rains, clean the exterior rearview mirrors in time to prevent the raindrops accumulated on the rearview mirrors from affecting the driver's sight.
- ◆ In case of driving failure due to heavy rain or lightning, it is necessary to park the vehicle in a place where there is no stagnant water to prevent the vehicle from being flooded, and turn on the hazard warning lamps to remind the vehicles behind.
- ◆ After driving out of a water-logged road section, depress the brake pedal lightly to check whether the brake function is normal. When the brake linings are wet, the braking efficiency will be significantly reduced, and accidents are likely to occur.



### CAUTION

- ◆ Before driving over a water-logged road section, determine the depth of water, and the water level shall not be high than the lower edge of the car body.
- ◆ The speed of the vehicle driven over the water-logged road section should not exceed the walking speed.
- ◆ After the rain, clean the vehicle in time to prevent the acid substance in the rainwater from corroding the body paint.

## Driving in hot seasons

In case of driving in hot seasons, please read and observe the following.

### DANGER

- ◆ Do not drive the vehicle when wearing slippers or high heels.
- ◆ In summer, the tire pressure will increase with the increase of temperature, and the tire is easily to burst. After driving for a certain distance, stop the vehicle to check the tire pressure and wait for the tire temperature to drop before driving.
- ◆ In hot summer, always check whether any vehicle circuit is short-circuited or aging, whether the connector is loose, whether the battery is in normal working condition, etc., to prevent the vehicle from spontaneous combustion.

### WARNING

- ◆ When parking, note to check whether there are dangerous objects and inflammables around.
- ◆ Try to avoid exposing the vehicle to the sun for a long time in the hot season, and do not place items such as lighters, paper scraps, cloth toys, perfumes, etc. on the instrument panel and its vicinity.

### CAUTION

- ◆ If it is unavoidable to expose the vehicle to the sun, park the vehicle with its front not exposed to the sun or use an aluminum foil sunshade. At the same time, the wiper arm can be raised to prevent the wiper blade from aging or even being deformed in advance.



## Driving in cold seasons

### Precautions for driving in cold seasons

In case of driving in cold seasons, please read and observe the following.

#### WARNING

- ◆ Before driving in cold seasons such as winter, carefully check the safety equipment in the vehicle such as steering wheel, brakes, lamps, instruments, horns, wipers, etc.
- ◆ The road is slippery after the snow in winter. During driving, be sure to keep stable speed and even operation. Do not perform unstable operations such as sudden acceleration, emergency braking, sudden steering, etc., and accelerate smoothly and keep driving the vehicle at medium or low speed.
- ◆ Be gentle when starting and accelerating to prevent tire slippage and sideslip.
- ◆ Always check the battery condition and keep the battery fully charged for starting.
- ◆ Use windshield washer fluid containing antifreeze, which can be purchased at the GAC AION sales store and ordinary auto parts stores.
- ◆ Have some equipment and tools available for use in an emergency. The following equipment is recommended: tire chains, window scrapers, sandbags, signal flashers, jumper cables, etc.

#### CAUTION

- ◆ Park the vehicle in a place where there is no snow or water accumulation to prevent the water from freezing and tearing the wheels.
- ◆ Place wooden boards at the tires to prevent snow from accumulating.
- ◆ Avoid parking the vehicle under a tree to prevent ice cubes from falling and damaging the vehicle.
- ◆ The wiper arm can be raised during parking to prevent freezing on the windshield and avoid tearing the wiper blade or damaging the motor during use.

### Using tire chains

Tire chains can be installed to the front wheels for driving in harsh conditions such as snowy or icy roads in winter.

#### WARNING

- ◆ Tire chains must be installed in pairs to the driving wheels.
- ◆ Do not install the tire chain to the emergency spare tire. If the front wheel is equipped with a spare tire and the tire chain needs to be installed, be sure to change the positions of the spare tire and the rear wheel.
- ◆ For installation of tire chains on all tires, ensure that the vehicle can be driven in a balanced manner in all weathers. It shall be borne in mind that after installation of tire chains, the car power may be insufficient. Even if the road surface is in good condition, drive carefully.
- ◆ While driving, neither exceed the specified speed limit of tire chains nor exceed 50 km/h, whichever is lower. Do not overspeed, accelerate sharply, decelerate sharply, or make sharp turns.



### **WARNING (Cont'd)**

- ◆ When decelerating, operate the brake pedal reasonably. Emergency braking on snowy or icy roads will cause the vehicle to drift and slip. Maintain an appropriate safety distance from the preceding vehicle, step on the brake pedal slightly, and bear in mind that installing tire chains to the tires can increase certain friction force, but can not prevent sideslip.
- ◆ Failure to do this will adversely affect the performance and safety of the vehicle.

### **CAUTION**

- ◆ Do not use tire chains on dry ground. After driving to snow-free roads, remove tire chains.

### **NOTE**

- ◆ Various countries and regions have different regulations on tire chains. Before installing tire chains, be familiar with the local laws and regulations.



## Tilting down of exterior rearview mirror when reversing\*

Some vehicles come with exterior rearview mirrors that can tilt down during reversing. During reversing, the exterior rearview mirror will automatically tilt down to a set angle, so that the driver can observe the surrounding environment.

The driver can turn on or off the tilting down function of the exterior rearview mirror through the center console display.

When the gear is shifted out of "R", the exterior rearview mirror will automatically reset.

### NOTE

- ◆ Set the tilting angle of exterior rearview mirror when reversing through the center console display.
- ◆ The exterior rearview mirrors may reset automatically at high reversing speeds.

## Reversing Parking Aid (RPA)

The RPA uses the ultrasonic sensor on the rear bumper of the vehicle to detect the distance between the rear of the vehicle and obstacles, assisting the driver to park the vehicle and adjust the vehicle position.

### Using RPA

When the gear is shifted to "R", the RPA will automatically be turned on, and when the RPA recognizes an obstacle within the detection range, it will start to alarm.

When the gear is shifted out of "R", the RPA will automatically be turned off.

### Turning on and off RPA audible alarm

For some models, the RPA audible alarm can be turned on or off via the center console display.

### WARNING

- ◆ The RPA cannot take the place of the driver's observation of the surrounding environment. The driver shall focus on safe reversing and position adjustment according to the practical conditions.
- ◆ The radar sensors have blind spots while they detecting obstacles. During reversing, the driver shall observe the surrounding environment carefully to avoid scratches or collisions.
- ◆ Please control the speed when reversing to avoid danger. When the RPA sends the continuous audible alarms, it indicates that the vehicle is extremely close to the detected obstacle, and reversing shall be stopped immediately to prevent an accident.



**i NOTE**

- ◆ When the reversing speed is too high, the RPA may not work.
- ◆ When the vehicle is reversing at a narrow place or on an uphill slope, the radar sensors may not detect railings, trees or slope surfaces, which is normal.
- ◆ The surface of some materials cannot reflect the signal from the radar sensor, so that the radar sensor cannot detect such materials or people wearing the clothing made of such materials.
- ◆ Noise sources outside the car may interfere with the radar sensor, making it impossible to detect any target.
- ◆ Please refer to "Parking - Parking Assist - SVM" for the precautions for using the radar sensor.

## Surround View Monitor (SVM)

The SVM processes the video signals collected by the front, rear, left and right panoramic cameras of the vehicle, and displays the panoramic image around the vehicle on the center console display to provide the driver with the information on the surrounding environment of the vehicle and to reduce blind spots during driving. It can also realize vehicle trajectory prediction, so that the driver can fully understand the running direction of the vehicle and ensure driving safety.

### SVM interface

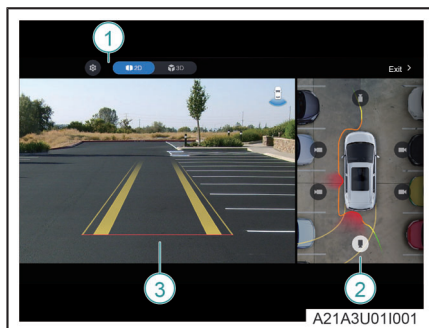

- ① Function button area
- ② 2D panoramic image display area
- ③ Single view /3D panoramic image display area

**i NOTE**

- ◆ The SVM interface is related to the model configurations, so please refer to the actual vehicle configurations.





## Turning on SVM

The SVM can be automatically turned on when the gear is shifted to "R".

Touch the  button on the center console display to enter the quick control interface, and then turn on the SVM.

## Settings of SVM

The SVM can be set in the function button area.

- ◇ Panoramic image interface switching
  - Touch the 2D/3D panoramic image button to change the SVM display effect.
- ◇ Function settings
  - Touch the icon  to display the settings interface. Trajectory, "P" gear exit time, transparent chassis (if available), panoramic view after activation of radars (if available), and panoramic view after activation of turn signal lamps can be set as needed.

## WARNING

- ◆ The SVM cannot take the place of the driver's observation of the surrounding environment. The driver shall focus on safe parking according to the practical conditions.

## CAUTION

- ◆ Keep the radar sensor surface clean and unblocked. If the radar sensor is dirty or blocked, that is, the radar sensor area is covered by rain, snow, mud or others, its related functions may fail to work, and the instrument may display related function disabled or fault information. To restore these functions to normal, clean the dirt.

## CAUTION (Cont'd)

- ◆ Do not attach accessories, stickers (including transparent stickers) or other objects on the radar sensor, camera or surrounding area.
- ◆ If the radar sensor is damaged or its direction changes, the instrument will display the alarm information. In this case, please contact the GAC AION sales store for inspection in time.
- ◆ The radar sensor, camera or the surrounding area should be free from strong impact. If the radar sensor and camera are strongly impacted, please contact the GAC AION sales store for inspection.
- ◆ If the bumper needs to be repainted due to scratches or color modification, avoid the area where the radar sensor is installed. The change of paint color may impair the performance of the radar sensor.
- ◆ Clean the radar sensor surface with a piece of soft wet cloth to avoid scratching it.
- ◆ Keep the surface of the camera clean and unblocked at all times. Clean the camera with a piece of soft wet cloth to avoid scratching the camera.
- ◆ Clean the radar sensor with a high-pressure cleaner gently in snatches and the nozzle shall be at least 10cm away from the sensor.
- ◆ Clean the camera with a high- pressure cleaner gently in snatches and the nozzle shall be at least 30cm away from the sensor.
- ◆ If water drops are on the surface of the radar sensors, the sensitivity of the sensors will reduce. Wiping off them with a piece of soft cloth can restore the sensitivity of the sensors.



### NOTE

- ◆ When the SVM is activated in a gear other than "R", the system will exit automatically after a period of time.
- ◆ When the gear is shifted from "R" to "D", and the vehicle is moving fast, the SVM will be turned off immediately.
- ◆ When the vehicle is in a gear other than "R", touching the exit button in the upper left corner of the SVM interface can exit the SVM.
- ◆ The radar sensor and camera must be adjusted and calibrated after the radar sensor or its mounting bracket or the camera or its mounting bracket is removed or installed, or the toe-in is adjusted, or a vehicle collision occurs.
- ◆ The adjustment and calibration of the radar sensor and camera requires the use of special tools and equipment. It is recommended to contact the GAC AION sales store for related work.
- ◆ Repair of the vehicle body or bumper may cause the direction of the radar sensor to change and affect the functions related to the radar sensor. It is recommended to contact the GAC AION sales store for inspection.
- ◆ The radar sensor is a precision component, which shall not be removed & refitted and repaired without authorization. Otherwise, GAC will not assume any responsibility for the damage arising therefrom.





### Electric Park Brake (EPB)

#### Manually applying or releasing parking brake

When the vehicle is in a gear other than “P”, depress the brake pedal and manually apply or release the parking brake via the center console display.

#### Automatic applying or releasing parking brake

When the seat belt is fastened, all the doors are closed, and the gear is shifted out of “P”, the EPB will be automatically released, and the indicator lamp  on the instrument will go out.

When the gear is “D” or “R”, the EPB is applied, and the accelerated pedal is depressed, the EPB will be automatically released, and the indicator lamp  on the instrument will go out.

When the vehicle is stopped stably, and the gear is shifted to “P”, the EPB will be automatically applied, and the indicator lamp  on the instrument will come on.

#### Application of dynamic emergency braking

If the service brake fails while the vehicle is running, you can try to continuously press the “P” button for emergency braking.

#### Towing mode

Turning on towing mode

- ◇ When the gear is “N”, the EPB is released, and the brake pedal is depressed, the towing mode can be turned on via the center console display.

Turning off towing mode

- ◇ The towing mode can be turned off via the center console display.

#### WARNING



- ◆ When the vehicle is running, do not apply the EPB for speed reduction unless necessary, as the EPB only applies braking force to rear wheels, which is likely to cause traffic accidents.
- ◆ Be sure to apply the EPB during parking.
- ◆ Do not use dynamic emergency braking unless necessary, as it is likely to cause traffic accidents. Moreover, the braking distance is longer than that generated during braking by depressing the brake pedal, and the service life of the parking brake system will be shortened.

#### CAUTION

- ◆ When the battery power is low, the system cannot release the EPB. If conditions permit, you can connect a jumper cable for emergency start, and then release the EPB. It is recommended to contact the GAC AION sales store for operation.
- ◆ If the vehicle continues to slide after the EPB has been applied on the slope, please depress the brake pedal, drive the vehicle to a flat road, and contact the GAC AION sales store for inspection in time.



**i CAUTION (Cont'd)**

- ◆ In the following cases, try to apply and release the EPB repeatedly. If the fault has not been eliminated, it is recommended to contact the GAC AION sales store for inspection.
  - If the EPB status indicator lamp  on the instrument keeps flashing, it indicates that the EPB is faulty.
  - If the EPB status indicator lamp  on the instrument comes on when EPB is not applied, it indicates that the EPB is faulty.
  - If the EPB fault indicator lamp  on the instrument comes on, it indicates that the EPB is faulty and its braking performance is degraded.

**i NOTE**

- ◆ If the EPB cannot be released when the gear is “P”, the instrument will give an alarm to remind you.
- ◆ If the “P” button is pressed during driving, the instrument will give an alarm message together with an audible beep alarm.
- ◆ When the EPB is applied or released, operation noise will be generated, which is normal.
- ◆ If the EPB has not been used for a long time, the system will perform automatic test, and motor running noise will be generated, which is normal.
 

The EPB will choose different application force strategies on different slopes. The EPB can realize parking on a slope with a maximum gradient of 30%. If parking on a slope with a gradient greater than 30%, there will be a risk of rolling back, and the EPB will be applied again, which is normal.
- ◆ After the EPB is applied, it can ensure that the vehicle does not roll back on a slope with a gradient of 30% within 5min. If rolling back occurs during this duration, the EPB will be applied again.
- ◆ To turn off the towing mode, if the center console display gets stuck and cannot be used, depress the brake pedal and long press (for more than 10s) the “P” button to turn off the towing mode.



## Closing all windows

### Closing right front door power window



Before getting out of the vehicle, make sure all windows are closed. If any window is not closed, it can be closed by operating the right front door power window button.

### Locking-sensitive window closing\*

After the locking-sensitive window closing function is enabled through the center console display, take all the keys and then leave and lock the vehicle, so all the windows are automatically closed.

### Remote window up

If you leave the vehicle with all the keys and find that the windows are not closed, you can close the windows via the remote window up function.

When all doors are closed, all the windows can be automatically closed by pressing and holding the locking button  on the smart key within the effective range. Release the locking button  on the smart key to stop closing of all windows.

### WARNING

- ◆ During operation on windows, make sure that no part of the driver and passenger's bodies will be pinched.
- ◆ The anti-pinch function may not work when the window is about to close completely.

### CAUTION

- ◆ It is forbidden to operate 2 or more windows at the same time. Otherwise, the vehicle may be damaged.
- ◆ It is prohibited to operate the same window in opposite directions by pressing the left front power window button and other passenger side power window buttons at the same time. Otherwise, the power window may stop working.

### NOTE

- ◆ If the power of the vehicle is turned off, and all doors are closed, the remote window down function can be enabled by pressing and holding the unlocking button  on the smart key.



## Closing sunroof



### Closing sunroof by operating sunroof button

Before getting out of the vehicle, make sure the sunroof has been closed. If it is not closed, it can be closed by operating the sunroof button.

### Locking-sensitive sunroof closing\*

After the locking-sensitive window closing function is enabled through the center console display, take all the keys and then leave and lock the vehicle, so the sunroof is automatically closed.

### Remote sunroof closing

If you leave the vehicle with all the keys and find that the sunroof is not closed, you can close it via the remote sunroof closing function. When all doors are closed, the sunroof can be automatically closed by pressing and holding the locking button  on the smart key within the effective range. Release the locking button  on the smart key to stop closing of sunroof.

### WARNING

- ◆ During operation on windows, make sure that no part of the driver and passenger's bodies will be pinched.
- ◆ The anti-pinch function may not work when the window is about to close completely.

### NOTE

- ◆ If the power of the vehicle is turned off, and all doors are closed, remote sunroof closing can be enabled by pressing and holding the unlocking button  on the smart key.

## Follow Me Home

The Follow Me Home provides light when you park at night and go home.

After the Follow Me Home function is turned on through the center console display, when the automatic headlamp function is turned on and the low beams automatically come on, the low beams will be on for a period of time and then go out after you leave the vehicle.

## Unlocking doors from inside

### Central unlocking



A21A3U01J001

The locked door can be unlocked by pressing the unlocking end of the central locking switch inside the vehicle.

### Unlocking by door inside handle

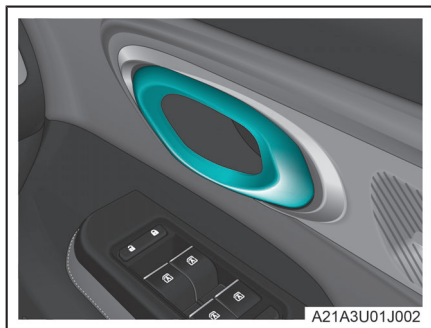

A21A3U01J002

The locked door can be unlocked by pulling the door inside handle.

### NOTE

- ◆ Do not frequently operate the central locking switch in a short time. Otherwise, the central locking switch may temporarily fail. In this case, after the door lock motor cools down, the central locking can be used again.
- ◆ With the vehicle stationary and in “READY” mode, if the driver unfastens the seat belt and sets the gear is shifted to “P”, the door is unlocked automatically.

## Opening doors from inside

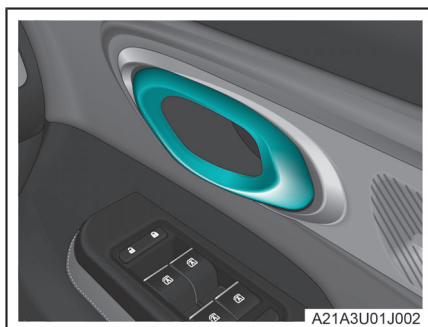

A21A3U01J002

After the vehicle is unlocked, the door can be opened by pulling the door inside handle.



### Safety notes before leaving

Before the driver leaves the vehicle, if the doors or windows are not closed, the instrument will give corresponding audible and visible prompts.





## Locking vehicle from outside

### Locking by smart key button

When the power of the vehicle is turned off, the driver and passengers leave the vehicle, all doors are closed, and there is no effective key in the vehicle, press the locking button  on the smart key within the effective range to lock the vehicle.

### Intelligent active locking

The vehicle can be automatically locked after the intelligent active locking function is enabled through the center console display, the power of the vehicle is turned off, the driver and passengers leave the vehicle, all doors are closed, there is no effective key in the vehicle, and the smart key is carried away from the vehicle.

### Locking vehicle via app\*

After the vehicle is linked to your AION APP account, you can lock the vehicle via the AION APP.

#### NOTE

- ◆ The horn alarm for vehicle locking/unlocking can be switched on/off in the center console display.
- ◆ Remote vehicle control is susceptible to the network environment and may not work sometimes. Please do not use the remote vehicle control function to have the smart key locked inside the vehicle. (if available)

## Exterior rearview mirror folding

### Electric folding and unfolding\*

Through the exterior rearview mirror adjusting interface in "My Car" menu on the center console display, the exterior rearview mirrors can be electrically folded or unfolded.

### Automatic folding and unfolding\*

After enabling or disabling of the automatic folding and unfolding of the exterior rearview mirror through the center console display.

- ◇ If the vehicle is locked, the exterior rearview mirror will be folded automatically.
- ◇ If the vehicle is unlocked, the exterior rearview mirror will be unfolded automatically.

### Manual folding and unfolding

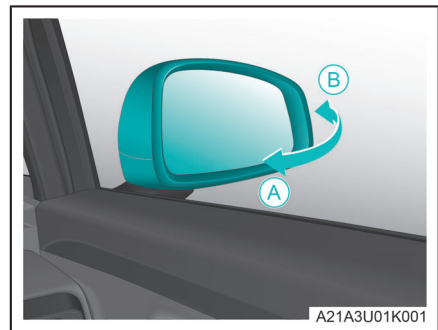

Pull the exterior rearview mirrors toward the rear of the vehicle (arrow A) to manually fold them.

Pull the exterior rearview mirrors toward the front of the vehicle (arrow B) to manually unfold them.

### **WARNING**

- ◆ Before driving, make sure the exterior rearview mirrors are unfolded, and adjust them to an appropriate angle.

### **CAUTION**

- ◆ Do not manually fold the rearview mirrors with electric folding function frequently, otherwise the internal folding mechanism will be damaged and the electric folding function will fail.



## Body anti-theft

### Body anti-theft

When the vehicle is locked, the vehicle will enter the anti-theft status.

### Anti-theft alarm

When the vehicle is locked and any door is illegally opened, the alarm will be triggered, the left and right turn signal lamps will flash, and the horn will sound.

If the anti-theft alarm is triggered for a period of time and the vehicle is still not unlocked, the vehicle will temporarily deactivate the alarm function.

### Alarm cancel

If the vehicle is unlocked or started using a valid key during alarming, the alarm will be automatically canceled.

### Switching of alarm mode

There are two anti-theft alarm modes, that is, audible and visual alarm, and visual alarm, the former of which is the default mode.

When the vehicle power is turned off, you can press and hold the locking and unlocking buttons on the smart key at the same time to switch between these two modes. If the switching is successful, the left and right turn signal lamps will flash simultaneously several times.

### CAUTION

- ◆ Do not modify or disassemble the body anti-theft system, otherwise the system will not work properly.

### NOTE

- ◆ Do not leave the key in the vehicle but carry it with you when leaving the vehicle.
- ◆ The body anti-theft system cannot prevent all thefts or guarantee the absolute safety of the vehicle.
- ◆ In order to prevent accidental alarm triggering or vehicle theft, please ensure the followings:
  - No one is in the vehicle.
  - The windows are closed before the vehicle is armed.
  - There are no valuables or other personal belongings in the vehicle.
- ◆ An alarm may be triggered in the following cases.
  - Door unlocking using the mechanical key.
  - Vehicle unlocking from inside after the vehicle is locked.
  - Door opening from inside after the vehicle is locked.



## Charging instructions

### Charging methods

This vehicle has two charging methods: AC charging and DC charging.

### Charge limit setting



According to your electricity needs, the charge limit can be set through the center console display.

#### NOTE

- ◆ The charge limit cannot be set for some models. The actual vehicle shall prevail.

### Charging status indication

The charging status of the vehicle can be known through the vehicle charging indicator lamp, instrument, charging pile, etc.

- ◇ Vehicle charging indicator lamp
  - The vehicle charging indicator lamp is the turn signal lamp. The vehicle charging status is as follows:  
When the charger is successfully connected, all the turn signal lamps will be on for a long time and then go out.  
When charging starts, the turn signal lamp flashes twice.
- ◇ Indications on instrument
  - After the charger is successfully connected to the charging port of the vehicle, the charger indicator lamp  on the instrument will come on.
  - When "Scheduled Charging" has been set but the scheduled charging has not yet started, if you open the door while the charger is connected, the instrument will display the scheduled charging indicator lamp  and the remaining time until the scheduled charging starts. (if available)
  - When "Scheduled Charging" has been set and the scheduled charging is in progress, the instrument displays green scheduled charging indicator lamp  and charging information. (if available)

#### ◇ Charging pile indication

- If a charging pile is used, the charging status of the vehicle will be displayed on the large screen of the charging pile. Please refer to the actual indication of the charging pile.

### Charging precautions

Please read and observe the followings carefully before charging your vehicle.

#### WARNING

- ◆ Please use the charging device that meet the regulatory requirements. Otherwise, it may result in charging failure, even causing vehicle damage or personal injury in severe cases. If necessary, please contact the GAC AION sales store.
- ◆ Do not modify or disassemble the charging device without authorization. When the charging device is faulty, please contact the manufacturer, and do not try to troubleshoot it by yourself.
- ◆ Do not use the charging device when it is damaged, rusted, wet, has foreign objects or is damaged in any way.
- ◆ Do not charge the vehicle when the surface of the charge cable or vehicle charging connector is cracked, the surface of the socket is damaged, rusted or cracked, or the connection is too loose.
- ◆ Do not use the charger and the vehicle charging port when they are deformed, blackened or ablated, otherwise the vehicle or charging device may be damaged, and in severe cases, personal injury may occur. If necessary, please contact the GAC AION sales store.
- ◆ The charging device must be well grounded when in use.
- ◆ Do not charge the vehicle in a place with flammable materials, and a ventilated place is recommended.



## WARNING (Cont'd)

- ◆ Minors are prohibited from using the charging device or from approaching the vehicle being charged.
- ◆ Do not charge the vehicle in the open air in thunderstorms. Otherwise, it may result in charging failure, even causing vehicle damage or personal injury in severe cases.
- ◆ When you need to charge the vehicle exposed to the rain, please confirm whether there is water entering the charging port. Do not charge the vehicle in the open air in thunderstorms. Otherwise, it may result in charging failure, even causing vehicle damage or personal injury in severe cases.
- ◆ During the charging, please ensure that the vehicle is properly connected to the charging pile, and it is forbidden to touch, unplug or insert the charger.
- ◆ Due to the danger of high voltage, it is recommended to keep a certain distance from the charging pile during charging, otherwise it may cause personal injury.
- ◆ During the charging, users with implanted medical equipment such as pacemakers need to stay away from the vehicle being charged to avoid electromagnetic interference affecting the operation of the medical equipment.
- ◆ During the charging, if you find any odor or smoke in the vehicle, please stop charging the vehicle immediately and contact the GAC AION sales store.
- ◆ After the charging, do not disconnect the charging device with wet hands or standing in water, otherwise it may cause electric shock and personal injury.

## CAUTION

- ◆ Do not directly pull the cable to move the charging device, and please handle it with care.

## CAUTION (Cont'd)

- ◆ When the instrument shows a low battery, please charge the vehicle as soon as possible. Charge the battery before its battery power is completely exhausted, otherwise the service life of the traction battery system will be affected.
- ◆ Before the charging, please check whether the charger and the vehicle charging port are clean and free of foreign objects. Otherwise the charging may fail or the vehicle charging port may be damaged.
- ◆ During the charging, do not use a high-pressure washing device to wash the charging port. Otherwise, it may result in charging failure, even causing damage to the vehicle or charging device.
- ◆ Make sure that the charging device is disconnected and the charging port cover is closed before starting the vehicle.

## NOTE

- ◆ Please read and observe the use instructions and precautions related to the charging device carefully.
- ◆ The vehicle must be parked before the battery is charged.
- ◆ When the battery temperature is low, it may not be possible to charge the battery at full power at the beginning of charging. As the battery temperature increases during the charging, the charging power increases.
- ◆ Charging the vehicle in a high-temperature or low-temperature environment will reduce the charging power and prolong the charging time.
- ◆ The vehicle cannot be charged while the software is being upgraded.



## AC charging

### AC charging

General operation steps of AC charging are as follows:

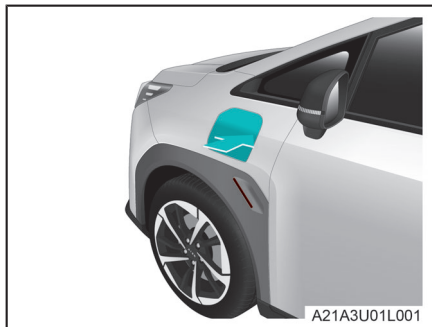

1. Unlock the vehicle, press the rear edge of the AC charging port cover located on the left side of the vehicle to open it.

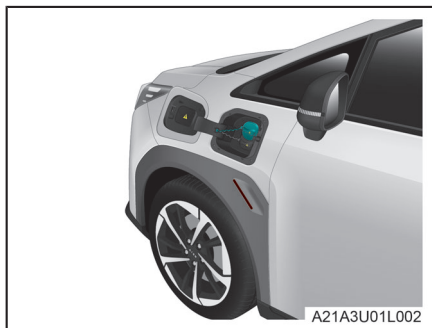

2. Open the AC charging port dust cap.

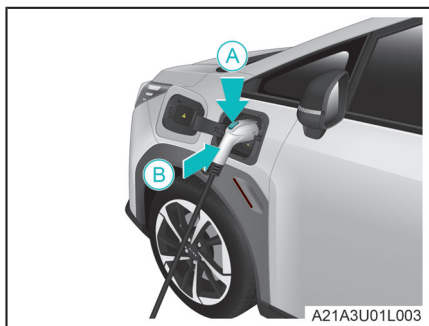

3. While pressing the unlocking button of the charger in the direction of arrow A, insert the charger in the direction of arrow B. After the charger is successfully connected, all turn signal lamps are on for a long time and then go off, and the charger indicator lamp on the instrument comes on.



4. Make relevant settings on the charging pile (such as start via APP), and start the charging pile.
5. Check the charging status through the instrument.
6. After charging, press and hold the charger unlocking button on the smart key to unlock the charger.

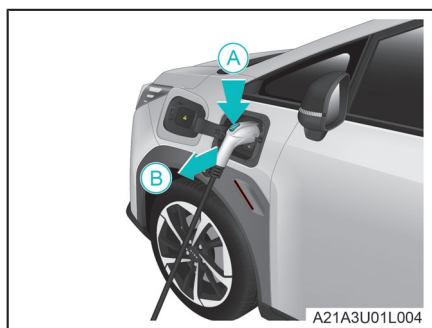

7. While pressing the charger unlocking button in the direction of arrow A, unplug the charger in the direction of arrow B.
8. Close the charging port dust cap and the charging port cover, and insert the charger back into the charging pile to complete the charging.

## NOTE

- ◆ The charging method of the home charger is basically the same as that of the AC charging pile.

## Scheduled charging\*

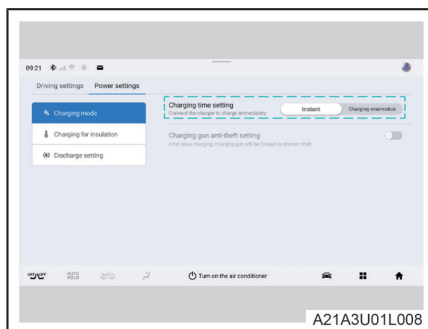

The scheduled charging function allows you to schedule the charging time of the vehicle. It is recommended that you schedule the charging time in the off-peak hours to save charging costs. To perform scheduled charging, follow the steps below:

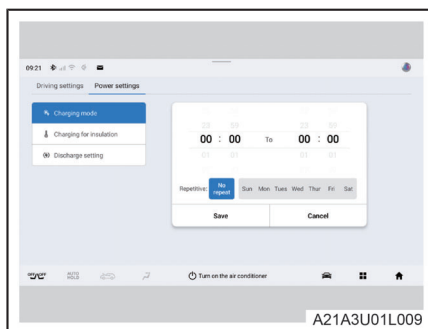

1. Select the charging mode as "Scheduled Charging" on the center console display.



2. On the scheduled charging time setting interface, set the scheduled charging time and repeat date. After the setting is completed, touch the "Save" button to finish this step.
3. Unlock the vehicle, press the rear edge of the AC charging port cover located on the left side of the vehicle to open it.
4. Open the AC charging port dust cap.

5. Connect the charger.
6. Connect the power supply. (Connect the household 220V power supply or start the charging pile according to the actual situation.)
7. Check the charging status.
  - The indicator lamp on the instrument  comes on, indicating that the vehicle is ready for scheduled charging. When the scheduled time has come, the indicator lamp  on the instrument comes on and the charger will start charging the vehicle.
8. When charging is finished, unlock and pull out the charger.
9. Close the charging port dust cap and the charging port cover, and insert the charger back into the charging pile.



## WARNING

- ◆ During the charging, make sure that the vehicle is properly connected to the power supply, and it is forbidden to unplug the charger.



## NOTE

- ◆ When the vehicle starts to be charged, the charger will be locked automatically. After the charging, the charger will be unlocked automatically (except when the charger is in the anti-theft state).
- ◆ When the anti-theft state of charger is enabled through the center console display, the charger will not be unlocked automatically after the vehicle is fully charged or keeping battery warm ends. If the charger is not unplugged for a long time after being unlocked, the charger will be locked automatically again. In this case, to unplug the charger, it needs to be unlocked again.



## NOTE (Cont'd)

- ◆ During the AC charging, if the charger cannot be locked or the electronic lock is unlocked abnormally, the charging will be ended.
- ◆ The AC charger can also be unlocked on the AION APP. (if available)
- ◆ If the charger is connected for a long time but charging fails, please unplug the charger in time to avoid low battery.
- ◆ Scheduled charging function is only applicable to AC charging. (if available)
- ◆ For some models, scheduled charging can also be set on the AION APP. (if available)
- ◆ It is recommended to use GAC AION charging pile for scheduled charging. Other charging piles available on the market may not support scheduled charging. (if available)
- ◆ When the charging mode is scheduled charging, if you want to charge immediately, you need to change the charging mode to "Charge Now". (if available)
- ◆ The charging-to-keep-warm function can be activated on the center console display to maintain the battery temperature, improve the battery range and vehicle performance while driving, and prolong the service life of the traction battery. In the case of AC charging in a low-temperature environment, the charging-to-keep-warm function will be activated automatically.
- ◆ For some models, you can set the intelligent charging-to-keep-warm reminder function on or off through the center console display.
- ◆ If other AC charging piles on the market are used, the charging-to-keep-warm function may not work properly.
- ◆ It is recommended to use GAC AION's dedicated charging pile or home power supply to charge the vehicle.





## NOTE (Cont'd)

- ◆ If you encounter special circumstances and cannot unlock the charger, you can unlock it through the emergency unlocking device of the charger. For details, please refer to the “Emergency treatment - Emergency treatment by owner - Emergency unlocking/locking” section.
- ◆ The above-mentioned charging method is a general method, which may be slightly different from the charging method indicated on the actual charging pile. Please follow the indications of the charging pile during actual charging.

## DC charging

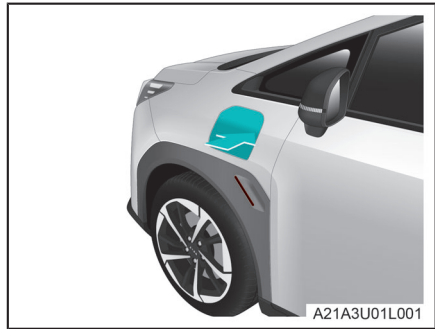

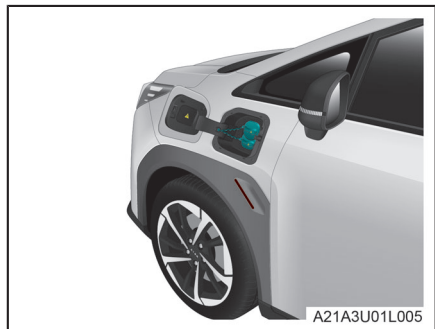

1. Unlock the vehicle, press the rear edge of the DC charging port cover located on the left side of the vehicle to open it.



2. Open the charging port dust cap.

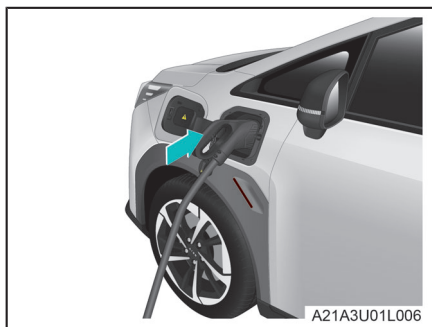



3. Insert the charger as arrowed. After the charger is successfully connected, all turn signal lamps are on for a long time and then go off, and the charger indicator lamp  on the instrument comes on.

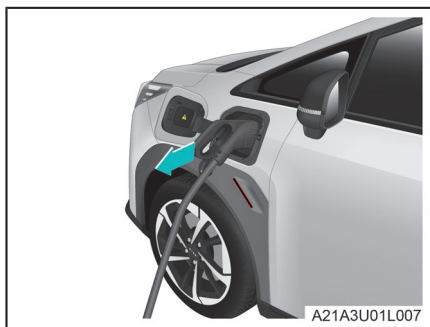

7. Pull out the charger as arrowed.
8. Close the charging port dust cap and the charging port cover, and insert the charger back into the charging pile to complete the charging.



4. Make relevant settings on the charging pile (such as scanning QR code or swiping a card), and start the charging pile.
5. Check the charging status through the instrument.
6. You can actively stop the charging as desired, or the charging can be stopped automatically when the vehicle is fully charged.

## WARNING

- ◆ During the charging, make sure that the vehicle is properly connected to the power supply, and it is forbidden to unplug the charger.
- ◆ After the DC charging, please unplug the charger in time.

## NOTE

- ◆ The above-mentioned DC charging method of the charging station is a general method, which may be slightly different from the charging method indicated on the actual charging pile. Please follow the indications of the charging pile during actual charging.

## External cleaning

Washing the vehicle frequently helps to protect its appearance.

The following conditions are likely to cause peeling of the paint layer or cause corrosion of the body and parts, and the vehicle needs to be cleaned in time:

- ◇ After driving along the coast.
- ◇ After driving on saline-alkali roads.
- ◇ Paintwork contaminated with coal tar or tree sap.
- ◇ Dead insects, insect droppings or bird droppings fallen on the paintwork.
- ◇ After driving in areas contaminated with coal ash, oil fumes, mineral dust, iron dust or chemicals.
- ◇ Liquids such as benzene and gasoline splashed on the paintwork.
- ◇ Severe dust or mud buildup on the vehicle.

### Manual vehicle washing

After driving, it is necessary to wait for the vehicle to cool down sufficiently in a cool place before washing it. Perform the manual vehicle washing in the following steps:

1. Make sure all doors and windows are closed.
2. Use a water pipe to clean the dirt on the vehicle surface, the mud and the salt and alkali on the vehicle bottom, and the recessed parts of the wheels.
3. Dip a sponge in the special detergent and wipe gently to remove the contaminants.

#### CAUTION

- ◆ Do not use the same sponge to wipe the whole vehicle, so please wipe the upper and lower parts of the vehicle with different sponges to avoid damage to the paintwork.

4. Clean tires with a special sponge and brush.

5. Thoroughly flush out the foam from the vehicle.
6. Do not wipe or press the body surface with force to avoid damage to the paintwork.
7. Use a blower to dry the accumulated water in the gaps of the vehicle, such as door weatherstrips, exterior rearview mirrors, charging port cover, headlamp gaps, etc.

#### WARNING

- ◆ Be careful not to cut your fingers when cleaning the carpet or chassis.

### Automatic vehicle washing

Before the washing, you should fold your exterior rearview mirrors, close all doors and windows, and consult with the wash station staff to choose the safest wash procedures for the paintwork. Be sure to unfold the exterior rearview mirrors before driving.

#### NOTE

- ◆ Certain types of brushes, unfiltered water, or machine-specific wash procedures in the automatic wash stations may scratch the paintwork and reduce its durability and gloss.

#### Environmental protection:

- ◆ The vehicle shall be cleaned at standard wash points to prevent sewage containing oil from being directly discharged into the sewer to pollute the environment.

### High-pressure vehicle washing

The water sprayed by a high-pressure cleaner has a certain pressure. To avoid water entering or damaging the vehicle, do not keep the nozzle close to the following parts:

- ◇ Gaps around the doors.
- ◇ Window edges.



- ◇ Radar and camera areas.
- ◇ Connectors on the chassis.

## CAUTION

- ◆ When cleaning the vehicle with a high-pressure cleaner, pay special attention to the working pressure and spray distance.
- ◆ Do not allow the nozzle to continuously spray the same area.

### Cleaning of special parts

- ◇ Aluminum-alloy hub
  - Use a special cleaning agent and a soft brush to clean dirt and dust from the hub.
  - Rinse off stains and residual cleaning agent with clean water.
  - Dry the hub with a piece of soft dry cloth or let it dry naturally.

## CAUTION

- ◆ Do not use acidic, alkaline or abrasive detergents.
- ◆ Do not use a hard brush.
- ◆ Do not use cleaning agents on the wheels when the wheels are hot (for example, after driving or after parking in hot weather).

- ◇ Lamps

- Use a special cleaning agent to clean the lamps.
- Gently wipe the lamp shade with a piece of soft cloth.

## CAUTION

- ◆ Wash the lamps carefully to avoid scratching or crushing the lamp shade with force.
- ◆ Do not use organic substances or hard brushes to clean the surface of the lamp, otherwise the lamp shade may be damaged.

Do not wax the lamp surface.

- ◇ Bumper

## CAUTION

- ◆ Do not scrub with abrasive detergents.



## Internal cleaning

### Cleaning of instrument panel and other interior trims

Wipe the instrument panel gently with a piece of moistened soft cloth during cleaning.

Please use mild neutral cleaners whenever possible, and avoid strong detergents or degreasing soaps.

#### CAUTION

- ◆ Do not wet the interior trims when cleaning them.
- ◆ Do not use a blade or other sharp objects to remove dirt from the interior trim surfaces, otherwise it may damage the interior trim surfaces.
- ◆ Do not wipe with excessive force, otherwise the interior trims may be damaged.

### Cleaning of leather

If the leather trims are not maintained or cleaned for a long time, the leather will become damp, moldy, dull, dry and cracked, which will affect both health and driving mood. Therefore, the leather trims must be carefully cleaned and maintained.

The leather cleaning steps are as follows:

1. Remove dirt and dust with a vacuum cleaner.
2. Use a piece of soft cloth moistened with leather cleaner to wipe off any remaining dirt and dust.
3. After cleaning, dry with a piece of soft dry cloth or let the leather dry naturally.

#### CAUTION

- ◆ Do not use ordinary detergents (such as washing powder, dish detergent, etc.) to clean the leather, otherwise it may damage the leather surface, resulting in corrosion or discoloration of the leather surface.

### Cleaning of switches

Use a small and soft brush to remove dust from buttons and switches.

Use a piece of soft cloth dampened with disinfectant to wipe the surfaces of the buttons and switches, and then use a piece of clean soft cloth to wipe off any remaining liquid.

#### CAUTION

- ◆ Do not use spray to clean the switch panel directly, otherwise the electrical consumers may be damaged.

### Cleaning of windows and rearview mirrors

Use a piece of soft cloth and special glass cleaner to clean the glass surfaces.

Dampen a piece of cloth with warm water and gently wipe the rear windshield in a direction parallel to the heating wires or antenna.

Clean the rearview mirrors with soapy water.

#### CAUTION

- ◆ Do not use glass cleaner to clean the rear windshield, as this may damage its antenna.
- ◆ Do not use abrasive cleaners to avoid damage to the glass and mirror surfaces.

### Cleaning of seat belt

Use a sponge or a piece of soft cloth dampened with mild soapy water or warm water to clean the seat belt. Regularly check whether the seat belt is free of excessive wear or cuts.

#### CAUTION

- ◆ Please wait till the seat belt dries completely before retracting it, otherwise its retractor may be damaged.



### Cleaning of carpet

Clean the dust first with a vacuum cleaner, and then scrub the carpet in circular motions with a sponge or brush dampened with a foam cleaner.

#### NOTE

- ◆ Do not use water, let the carpet dry after cleaning, and keep the carpet as dry as possible.

### Precautions for internal cleaning

Please read and observe the followings when cleaning the interior of your vehicle.

#### DANGER

- ◆ Do not let the airbag components or wires in the vehicle get wet, otherwise the airbag may fail to deploy or malfunction, resulting in serious injury or even life-threatening danger.
- ◆ Do not use polishing wax or polishing cleaner to clean the instrument panel, otherwise the instrument panel may reflect light on the windshield, obstruct the driver's visibility, and cause serious injury or even life-threatening danger.

#### CAUTION

- ◆ Do not spill liquids such as cleaners into the interior of the vehicle, otherwise it may cause the electrical components to get wet and malfunction. If any liquid is accidentally spilled, wipe it up immediately.
- ◆ Do not use strong acid or alkali cleaners.
- ◆ If you need to use a cleaning agent, please read the instructions of the cleaning agent carefully and follow them strictly.



## External maintenance

The external maintenance shall be based on the external cleaning, and shall be carried out after the external cleaning.

### Waxing

In order to maintain the gloss of the vehicle, it is recommended to polish and wax the body. The body waxing is required in the following cases:

- ◇ When the body surface does not repel water well.
- ◇ When the body surface is exposed to water in a large area, and the water does not form droplets and adheres to the surface.

It is recommended to wax the body on a regular basis and contact the GAC AION sales store regularly (once a quarter) to maintain the vehicle, so as to restore the gloss of the body paintwork in time.

### Cleaning of residual wax

After the body is waxed, use a special cleaner and a piece of clean cloth to remove the wax remaining on the glass so as not to affect the visibility.

### Paintwork damage

If there is no obvious damage to the paintwork, please do not carry out secondary painting to prevent the paint color from being incompatible or not well matched.

For small areas of paintwork damage (such as scratches or stone impact marks), please cover them with paint as soon as possible before rust occurs.

If the damaged paintwork has been rusted, the rust must be completely removed, and the anti-corrosion primer and varnish shall be applied to the rusted position. It is recommended to contact the GAC AION sales store for treatment.

### Maintenance of wheels

Regular maintenance of the wheels can keep the surface finish of the wheels and prolong their service life.

It is recommended to use high-quality hard wax on aluminum-alloy wheels every three months, or regularly clean steel wheels with a special sponge.

### WARNING

- ◆ Do not treat the wheel surfaces with vehicle polish or other abrasive cleaners.
- ◆ The wheels with damaged protective coating on surface must be repaired in time.

### Maintenance of external plastic parts

External plastic parts are generally washed with clean water, soft cloth and soft brushes. If they cannot be cleaned, please use the special plastics cleaner.

### CAUTION

- ◆ Do not use abrasive cleaners to clean plastic parts, as this may damage the plastic parts.



## Internal maintenance

The internal maintenance shall be based on the internal cleaning, and shall be carried out after the internal cleaning.

### Maintenance of instrument panel

After the instrument panel is cleaned, in order to slow down the aging of plastic parts such as the instrument panel, a layer of protective wax can be applied to the instrument panel to prolong the service life of the plastic material.

### Maintenance of leather

Leather trims can be sprayed with a special leather wax and polished with a piece of dry cloth.

### Maintenance of window glass

After the window glass is cleaned, glass coating products can be sprayed on it to prevent fogging of the windows in rain and snow or in winter.

### Maintenance of weatherstrips

Regular maintenance of the rubber weatherstrips of the doors, windows and other parts of the vehicle is intended to maintain their flexibility and prolong their service life. Such maintenance can also improve the tightness, make the door easy to open, reduce the impact sound of closing the door, and prevent freezing in winter. The maintenance steps of the weatherstrips are as follows:

1. Use a piece of soft cloth to remove dust and dirt from the surfaces of the weatherstrips.
2. Apply special protective agent to rubber weatherstrips regularly.

## Tire maintenance

Defective tires will increase the risk of driving, and you should get into the habit of checking your tires before driving.

### Tire pressure

Contact the GAC AION sales store to check the tire pressure. For the vehicles equipped with spare tires, please regularly check the spare tire pressure.

If you find that the tire valve cap is missing, install a new one in time.

#### DANGER

- ◆ Insufficient tire pressure exacerbates tire deflection, and tires are extremely prone to overheating, which may lead to tread separation and tire burst. Too high or low tire pressure can accelerate tire wear, reduce vehicle maneuvering stability, and easily cause traffic accidents, injuries and even death.

#### WARNING

- ◆ Take care to maintain proper tire pressure to prevent accidents.

#### NOTE

- ◆ For inspection of tire pressure, the tire must be in a cold state. When the temperature increases, the tire pressure can be slightly higher than the specified value, and it is not necessary to reduce the tire pressure.
- ◆ When checking the tire pressure or tire inflation, balance the weight of occupants and luggage, avoid slopes and adjust the tire pressure according to vehicle load.
- ◆ After checking the tire pressure or tire inflation, be sure to put the tire valve cap back on the valve core.





## Hidden damage

Damage to tires and rims often occurs in a hidden way, and abnormal vibration or deviation of the vehicle during driving may indicate tire damage. If you suspect that the tires are damaged, be sure to reduce the speed immediately and stop to check the tires for damage. If the damage is not visible from the outside, it is recommended to contact the GAC AION sales store to check the tires as soon as possible.

## Precautions for wheel failure

When driving over curbs or similar obstacles, keep a slow speed in the vertical direction of the obstacles as much as possible.

Regularly check the damage of tires (such as splitting, abrasion, shedding, deformation or bulging).

Regularly remove debris embedded in the grooves of the tire pattern.

## New tires and wheels

Make sure that the dimensions, load range, rated speed and structure type of new tire are the same as those of original one.

Replace at least two tires on the same axle at the same time, rather than only one tire individually.

Do not use tires of different dimensions or types, and do not mix summer tires, all season tires and winter tires in use.

Once wheels are installed, check whether the tightening torque of the wheel bolts meets the requirements.



### WARNING

- ◆ Never use tires that do not meet the specifications of this vehicle and have not passed the national product certification, otherwise it may cause accidents.

## Winter and summer tires

- ◇ Winter tires
  - Winter tires have good grip performance on icy roads and in low-temperature environments, and have excellent braking ability, which can improve driving safety in winter.
  - It is recommended to use winter tires while driving in icy or snowy days in winter or when the temperature is below 7°C.
  - Use only radial winter tires of same dimensions, load range and rated speed as original ones and approved for this vehicle.



- The tread depth of winter tires shall not be less than 4mm.
- After installation of tires, check the tire inflation pressure.
- ◇ Summer tires
  - Summer is a rainy season. The tire tread depth directly affects the driving safety in rainy days. The tread depth of summer tires shall not be less than 3mm.
- ◇ Winter and summer tires are designed according to their respective typical lane conditions under the corresponding seasonal conditions. It is recommended to use winter tires in winter and summer tires in summer, otherwise the adhesion and braking ability will be poor.
  - If summer tires are used in severe cold conditions, cracks may appear on the tires, resulting in tire damage, increased tire noise, and loss of balance.
  - Winter tires may lead to decreased traction force of the vehicle on dry roads, increased road noise and shortened service life of tread. Please pay attention to the performance change of the vehicle in terms of maneuvering and braking after the winter tires are used.
  - The maximum speed for winter tires is relatively low. Do not exceed the allowable maximum speed for the tires during driving.
  - When driving in atmospheric temperature rising above 7°C, in order to ensure driving safety and performance, please replace the winter tires with summer tires in time.

### Service life of tires

Service life of tires depends on tire pressure, driving style and tire assembly conditions.

If the front tires are worn more serious than the rear tires, it is recommended to perform tire rotation for the front and rear wheels, so as to make the service life of all tires about the same. (For tire rotation, please refer to the “Emergency treatment - Emergency treatment by owner - Tire replacement” section)

### Wheel balance

The wheels of the new vehicle have been dynamically balanced, but during the driving, various influences may cause the wheels to appear unbalanced; when the steering wheel shakes during driving, the wheels may be unbalanced, and the wheels need to be dynamically balanced.

The unbalanced wheels may cause excessive wear on the steering system, wheel suspension mechanism and tires.

The dynamic balance must be performed after installation of new tires or repair of tires.

### Wheel alignment

Wheel misalignment will cause uneven and excessive wear of the tires, affecting driving safety. If uneven and excessive wear of the tires is found, please go to the GAC AION sales store to check the wheel alignment as soon as possible. Four-wheel alignment is required in the following cases:

- ◇ There are defects in driving performance, such as deviation.
- ◇ Chassis is damaged in accidents and related parts are replaced.
- ◇ Suspension parts are removed or replaced.
- ◇ Uneven and excessive tire wear occurs.



## Tires marked with rolling direction

Some tires are marked with arrows or characters indicating the rolling direction on the sides, so these tires must be installed in the marked rolling direction. If the tire rolling direction is reversed, there may be dangers such as tire jitter, increased noise, accelerated wear, and significantly weakened grip during driving.

## Instructions for storing tires

If there is no rolling direction mark on the side of the tire, before removing the tire, make a mark on the tire to indicate the rolling direction, and refit the tire according to the mark to ensure the rotation direction and the dynamic balance of the wheel are unchanged.

The removed wheels or tires shall be stored in a dry place, preferably in a dark place.

The tires mounted on the rims shall not be stored upright, and the tires not mounted on the rims shall be stored upright (the tread surfaces shall touch the ground).

## Precautions for use of tires

Please read and observe the followings when using and maintaining your tires.

### WARNING

- ◆ Within the first 500km, the road adhesion of new tires is unlikely to reach the best condition. Therefore, the vehicle shall be driven carefully at a moderate speed to prevent accidents.
- ◆ If tires burst or leak when the vehicle is running, it is very easy to cause serious traffic accidents.

### WARNING (Cont'd)

- ◆ Never use damaged tires and wheels, or use tires of which the treads have been worn to the wear indicators.
- ◆ Do not use old tires that have been used over six years.
- ◆ Do not use old wheels and tires of unknown origin under any circumstances, otherwise, the driver may lose control of the vehicle and cause traffic accidents when driving.
- ◆ Do not use recycled tires. The carcass of these tires may degrade as the service time passes, and the durability may also be restrained, impairing the driving safety.

### CAUTION

- ◆ Be careful not to expose the tires to chemicals, oil, grease, fuel and brake fluid.
- ◆ If it is found that the vehicle is abnormally vibrating or deviating, stop the vehicle immediately and check whether the tires are damaged.
- ◆ Inadequate road adhesion of tires not subject to running-in period or excessively worn can directly affect the braking effect. If uneven and excessive wear of the tires is found, please go to the GAC AION sales store for inspection as soon as possible.



## Corrosion protection measures

The vehicle has effective corrosion protection. However, in order to reduce the risk of corrosion, please observe the followings:

- ◇ Perform regular vehicle washes to keep the body clean and prevent corrosion.
  - If you drive on salty roads in winter, or live by the sea, please have your vehicle be carefully cleaned at least once a month to reduce corrosion.
  - Please carefully clean the chassis on a regular basis to remove mud and dirt adhering to the chassis and wheelhouses.
  - Clean the chassis in time after driving on icy and snowy roads to prevent the residual deicing salt from corroding the vehicle.
- ◇ Check the paint and trims of the body.
  - If the paint layer is found to be chipped or cracked, it is recommended to contact the GAC AION sales store for repairs to prevent corrosion.
- ◇ Keep the interior of the compartments dry.
  - Moisture and dust tend to accumulate under the carpet, so the underside of the carpet shall be checked frequently to ensure it is dry and clean to prevent corrosion.
  - When chemicals, detergents, fertilizers, salts and others are transported, they must be stored in appropriate containers, and if spills or leaks are found, they must be cleaned immediately and the compartment must be kept dry.
- ◇ Use mudguards.
  - When the vehicle runs in saline-alkali areas or on gravel roads, the mudguards can be used to prevent the adhesion of saline-alkali substances and the impact of gravels on the vehicle components.
- ◇ Park the vehicle in a well-ventilated garage or a roofed area, and do not park it in a damp and airtight environment.



## Long-term storage of vehicle

A good parking environment helps prevent deterioration and makes it easy to re-operate the vehicle. If possible, park the vehicle indoors. If the vehicle needs to be stored for a long time, please make the following preparations:

- ◇ Before parking, make sure that the battery SOC of the vehicle is 50%~70%.
- ◇ Carry out the maintenance every three months, and before parking, charge the traction battery by slow charge and then discharge it to 50%~70%.
- ◇ Keep the vehicle parking environment as dry and ventilated as possible, away from heat sources.
- ◇ Thoroughly wash and dry the outer surface of the body.
- ◇ Clean the interior of the vehicle to make sure carpet, interior trims, etc. are completely dry.
- ◇ Open the windows on one side slightly (in the case of indoor storage).
- ◇ Disconnect the negative terminal of the low voltage battery.
- ◇ Pad the front wiper blades with a towel or a piece of cloth so that they do not come into contact with the windshield.
- ◇ Cover the body with a car cover made of a "porous material" such as cotton. Non-porous materials such as plastic sheeting may trap moisture and damage the body paintwork.
- ◇ If possible, start the vehicle for a short period on a regular basis (preferably once a month).
- ◇ If the vehicle has been parked for more than three months, please confirm whether the instrument has any alarm before using it again, and if any, contact the GAC AION sales store for inspection and repair.



## Opening and closing hood

### Opening hood

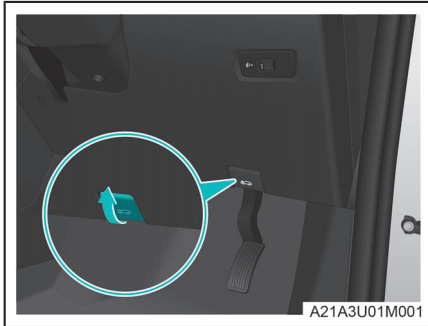

1. Pull up the hood release lever in the cab, and then the hood 'clicks' and pops up slightly.

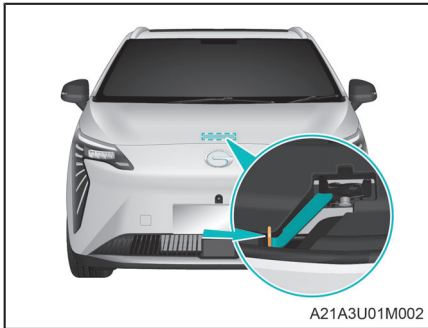

2. Stand in front of the vehicle (facing the front end of the vehicle), put your hand into the area to turn the secondary release lever as arrowed in the figure, and then lift the hood upward at the same time.

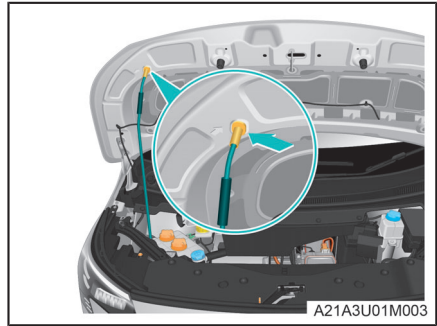

3. Take out the stay bar and insert it into the position as shown in the figure to fix the hood.

### Closing hood

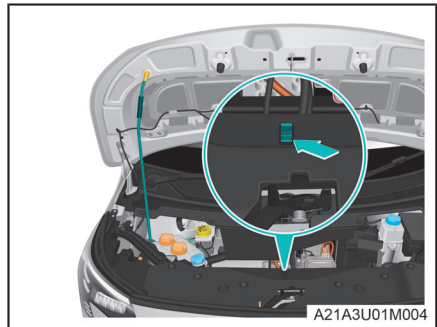

1. Hold the hood by hand, and take away the stay bar to fix it to the position as shown in the figure.
2. Lower the hood to a height of about 30cm above the front grille, and release both hands to let the hood fall freely so as to be locked.

## WARNING

- ◆ After opening the hood, make sure that the stay bar firmly supports the hood to prevent the hood from being closed suddenly.
- ◆ Before driving, ensure that the hood is closed and locked, otherwise, it may suddenly open during driving, resulting in accidents.

## CAUTION

- ◆ Before closing the hood, be sure to fix the stay bar with the retaining clips. If the hood is closed and the stay bar is not properly returned to the original position, the hood may be deformed.

## NOTE

- ◆ Before closing the hood, make sure that no tools, waste cloth, etc. are left in the motor compartment.

## Adding windshield washer fluid

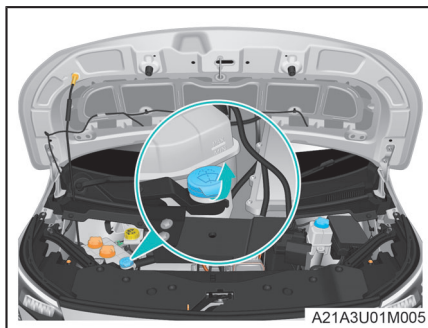

Open the hood, open the washer fluid reservoir cap as arrowed, and check the washer fluid in the reservoir. If the washer fluid level is too low, please add the washer fluid or a mixture of washer fluid and water.

## WARNING

- ◆ Do not add any additives to the windshield washer fluid, otherwise oil stains or other debris will be left on the windshield during cleaning, which will affect the driver's visibility.
- ◆ If the windshield washer fluid spills on your hands or eyes, rinse immediately with clean water.

## CAUTION

- ◆ Do not use other liquids in place of washer fluid, as this may cause streaks on the vehicle paintwork.
- ◆ Do not mix windshield washer fluid and cleaning agent, as this may block the windshield washer nozzle.

## NOTE

- ◆ It is difficult to wash the windshield thoroughly with pure water.



## Checking coolant

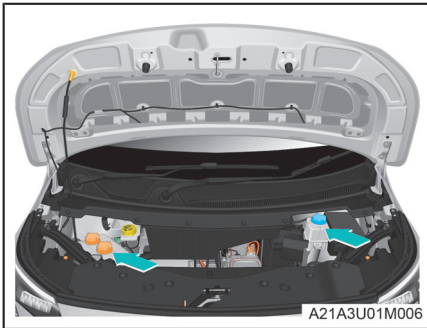

Open the hood, and check the coolant level in the expansion tank as shown. If it is below the “MIN” mark, please fill the expansion tank with coolant to the level between the “MIN” and “MAX” marks in time.

### WARNING

- ◆ Do not remove the filler cap when the vehicle is hot to avoid burns.
- ◆ The coolant must be stored in marked containers out of the reach of children.
- ◆ If the coolant spills on your hands or eyes, rinse immediately with clean water.

### CAUTION

- ◆ If the coolant is spilled during refilling, wipe it off with a rag to prevent damage to the parts or paintwork.
- ◆ It is recommended to go to the GAC AION sales store to add or change the coolant.
- ◆ Use the same coolant as the original one, and do not mix different types of coolant.

### NOTE

- ◆ The status of the expansion tank and the number of access panels depend on the model, and the figure is for reference only.
- ◆ Make sure that the level in the expansion tank is between “MIN” and “MAX” marks after refilling.

### Environmental protection:

- ◆ Always dispose of the coolant in compliance with environmental laws and regulations, and do not dump it directly into garbage heaps, sewers, or on the ground.





## Checking brake fluid

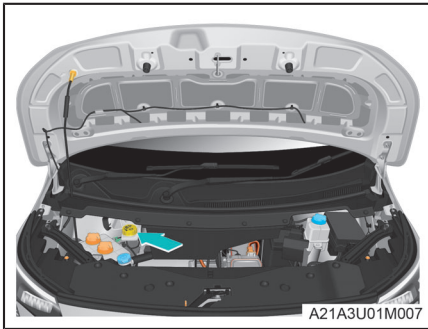

Open the hood, and check the brake fluid level in the brake fluid reservoir. If it is below the “MIN” mark, please fill the brake fluid reservoir with brake fluid to the level between the “MIN” and “MAX” marks in time.

### **WARNING**

- ◆ The brake fluid must be stored in marked containers out of the reach of children.
- ◆ If the brake fluid spills on your hands or eyes, rinse immediately with clean water. If you still feel unwell, seek medical attention.

### **CAUTION**

- ◆ Do not spill the brake fluid on the paintwork. If the brake fluid is spilled on the paintwork, please wash it with water immediately.
- ◆ It is recommended to go to the GAC AION sales store to add or change the brake fluid.
- ◆ Use the same brake fluid as the original one, and do not mix different types of brake fluid.

### **NOTE**

- ◆ The status of the brake fluid reservoir depends on the model configuration, so please refer to the actual vehicle.

### **Environmental protection:**

- ◆ Always dispose of the brake fluid in compliance with environmental laws and regulations, and do not dump it directly into garbage heaps, sewers, or on the ground.



## A/C filter

The A/C filter is located behind the glove box. Regular cleaning of the A/C filter can keep the air in the compartments fresh.

### CAUTION

- ◆ To clean the A/C filter, you need to remove the glove box first. In order to avoid damage to the vehicle by yourself, it is recommended to contact the GAC AION sales store for operation.

### NOTE

- ◆ Clean the A/C filter element according to the “Maintenance instructions - Regular maintenance” section in the Warranty and Maintenance Manual. In dusty or heavy traffic areas, the cleaning interval shall be shortened accordingly.
- ◆ Before using the A/C system, make sure that the A/C filter element is properly installed.



## Checking and replacing fuse

All circuits on the vehicle are fused to prevent damage to electrical consumers due to short circuits or overloading. These fuses are installed in two fuse boxes, that is, the motor compartment fuse box and the instrument fuse box.

If any electrical component fails to work, a fuse may be blown. If this happens, check and replace the fuse if necessary.

Check and replace the fuse in the following steps:

1. Turn off the vehicle power switch.
2. Open the fuse box cover.
  - Motor compartment fuse box

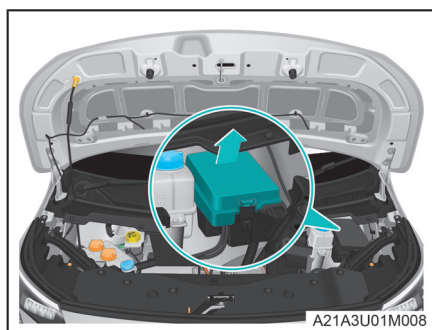

The motor compartment fuse box is located at the right rear of the motor compartment (when facing the front end of the vehicle). You can open the hood, and press the buckles on both sides of the fuse box while pulling up the fuse box cover to check the motor compartment fuse.

- Instrument fuse box



The instrument fuse becomes accessible after the driver side lower guard plate assembly is removed.

3. Remove the fuse from the fuse box.
4. Check the wire inside the fuse and replace it if it is blown.
5. If the fuse is blown, replace it with a spare fuse of the same amperage rating (indicated on the motor compartment fuse box cover).
6. After replacing the fuse, check whether the electrical components restore normal work. If the operation returns to normal, install the motor compartment fuse box cover or the driver side lower guard plate assembly.

### CAUTION

- ◆ Never use a fuse higher than the amperage rating, or substitute any other item for the fuse, as this may result in the vehicle damage, fire or personal injury.
- ◆ Do not replace the fuse with a wire, even temporary replacement is not allowed.
- ◆ Do not modify the fuse or fuse box.
- ◆ Keep the inside of the fuse box clean and protect it from moisture.
- ◆ If the correct fuse is installed but the fuse is still blown within a short time or the electrical components do not restore normal work, it indicates that the vehicle may have an electrical system failure, and it is recommended to contact the GAC AION sales store for repair.



## Low voltage battery maintenance

### Checking low voltage battery

Frequently check the battery surface and the positive and negative terminals, ensuring that the positive and negative terminals of the battery are not loose or corroded.

Check the appearance of the battery for cracks, swelling, etc. If there is the above symptom, it is recommended to contact the GAC AION sales store for repair as soon as possible.

For more inspection and maintenance items, please refer to the "Maintenance instructions - Regular maintenance" section in the Warranty and Maintenance Manual.

### Replacing low voltage battery

Always use the battery of the same type and specification to replace the battery. It is recommended to contact the GAC AION sales store to remove, replace or install the battery.

### Environmental protection:

- ◆ The recycling of the battery must be carried out by a qualified unit to avoid pollution to the environment and damage to the operator.

### Vehicle storage

Due to natural discharge and the wear-out effect of certain electrical consumers, the power stored in the battery is gradually depleted even when the vehicle is not in use. If the vehicle is not in use for a long time, the battery power may be exhausted and the vehicle may fail to be started. Therefore, the negative terminal of the battery should be disconnected, and the battery power should be checked regularly. If necessary, start the vehicle to charge the battery.

### WARNING

- ◆ When removing the battery terminals, be sure to remove the negative terminal first. If the positive terminal is removed and it touches any metal in the surrounding area, it may spark and cause a fire, and possibly an electric shock, resulting in serious injury or even death.
- ◆ Before reconnecting the battery, turn off all electrical consumers on the vehicle. Connect the positive terminal first and then the negative terminal. Never install the terminals in the wrong order, as there will be a risk of fire.
- ◆ The battery shall be kept away from heat sources and open flames, and ventilation shall be maintained during charging and use, otherwise it may cause fire or personal injury.
- ◆ Always check whether the battery terminal clamps are firm and in good contact to avoid sparks and battery explosions.
- ◆ The hydrogen gas generated when the battery is charged is flammable and explosive, so when using a charger to charge the battery, be sure to remove the battery.
- ◆ Always wear safety goggles when working on the battery and be careful not to let any battery electrolyte come into contact with your skin, clothing or body.
- ◆ If the battery electrolyte comes into contact with your skin or eyes, rinse immediately with water and seek medical attention. The contact area shall always be covered with a damp sponge or a piece of damp cloth until you see a doctor.



## **WARNING (Cont'd)**

- ◆ Always wash your hands after working on the battery bracket, terminals, and other battery-related parts.
- ◆ Do not lean over the battery.
- ◆ Keep children away from the battery.

## **CAUTION**

- ◆ Avoid battery overcharging or long-term power loss.
- ◆ Avoid long-term high-current discharge of the battery.
- ◆ Firmly install the battery on the vehicle to avoid vibration.
- ◆ The oxides and sulfates produced by the battery terminal clamps must be cleaned up, and Vaseline shall be applied to avoid re-corrosion.
- ◆ When the vehicle runs in a cold region, do not discharge the battery completely to avoid freezing of the battery electrolyte.

## **NOTE**

- ◆ The automatic battery charging function can be activated, provided that the vehicle is stationary, the anti-theft system of vehicle is activated, all the doors are locked, etc.
- ◆ Try to avoid using electrical consumers for a long time when the vehicle is not started, so as not to cause the battery power loss.

## Maintenance of traction battery

### Precautions for use and maintenance of traction battery

## **DANGER**

- ◆ It is strictly forbidden to remove, disassemble or modify the traction battery, or use the traction battery for other purposes.
- ◆ The traction battery shall be placed out of the reach of children.
- ◆ The traction battery shall be kept away from fire sources to avoid fires or explosion.
- ◆ It is forbidden to spray, trample, hit or destroy the traction battery to avoid leakage, fires or explosion of corrosive chemicals.
- ◆ It is strictly forbidden to touch the positive and negative poles of the traction battery case with both hands at any time.
- ◆ It is strictly forbidden to perform operations such as squeezing, piercing or burning that damage the battery system for the traction battery.
- ◆ If the traction battery suffers severe mechanical damage, resulting in the exposure of internal high-voltage components, there is a risk of violent combustion and electric shock, which may cause serious casualties and environmental pollution.
- ◆ The traction battery damage or electrolyte leakage may cause a fire. If it happens, it is recommended to contact the GAC AION sales store immediately. Do not touch the leaked electrolyte with hands. If the skin or eyes come into contact with the electrolyte accidentally, rinse the skin or eyes immediately with plenty of water, and seek medical attention immediately.
- ◆ Since the traction battery pack is a high-voltage component, it is strictly prohibited to open or repair the traction battery pack by non-professional personnel without authorization.



## CAUTION

- ◆ The traction battery is located at the bottom of the vehicle. During driving, take care not to have the traction battery impacted or flooded.
- ◆ The vehicle not used for a long period of time shall be subjected to scheduled maintenance; otherwise, the performance degradation of the traction battery will occur.
- ◆ In order to give full play to the performance of the traction battery, try to avoid full charging and full discharging.
- ◆ The operating environment of the vehicle shall be dry, free of corrosive, explosive or destructive insulation gases or conductive dust, and away from heat sources.
- ◆ Avoid frequently using the high-power DC fast charge method to charge the vehicle, because it will affect the life of the traction battery.

## NOTE

- ◆ The vehicle uses the traction battery to store electric energy and can be charged repeatedly. Ensure that the traction battery is fully charged before driving. During driving, the traction battery is discharged gradually. When the traction battery is low, it must be charged; otherwise, the vehicle cannot be driven.
- ◆ The time required to charge the traction battery is affected by the charging power, battery SOC, battery temperature, vehicle service time, ambient temperature and other conditions.

## NOTE (Cont'd)

- ◆ For a new vehicle, when the traction battery is in the normal state, due to driving styles (such as frequent acceleration and deceleration), road conditions (such as long-time continuous climbing) and temperature (such as low temperature), the range of this vehicle will be appropriately reduced, which is normal.
- ◆ In summer, park the vehicle in a cool environment and try to avoid direct sunlight.
- ◆ When the chassis area of the vehicle is bumped, it is recommended to contact the GAC AION sales store for inspection and maintenance.

### Precautions for LFP traction battery

If your vehicle is equipped with a LFP traction battery, please read and observe the followings.

## NOTE

- ◆ To keep the vehicle traction battery in the best condition, please fully charge the traction battery at least once a week, and fully charge it after deep discharge once every 3~6 months. (Deeply discharge the battery to make its SOC below 10%)
- ◆ When the vehicle detects that you have not performed full charge operation for a long time, it may automatically perform a self-test, and the self-test process will consume some power.



### Recycling of traction battery

The traction battery is a safety component. For maintenance, repair, removal, installation, reuse or disposal of the traction battery, it is recommended to consult the GAC AION sales store.

When the traction battery needs to be replaced or scrapped, it is recommended to contact the GAC AION sales store for recycling and disposal. The sales store will record the vehicle and owner traceability information through the traceability system.



#### **DANGER**

- ◆ If the traction battery is not handled correctly, electric shock and serious injury or even death may be caused. The removal, disassembly and discarding of the traction battery without authorization will cause pollution to the environment, and the vehicle owner shall bear the corresponding responsibility for the resulting environmental pollution or safety accidents.



#### **WARNING**

- ◆ When the vehicle must be scrapped, it is recommended to contact the GAC AION sales store for recycling and disposal. If you come into contact with high-voltage parts, cables and their connectors and other high-voltage components when removing the traction battery without authorization during vehicle scrapping, there may be a serious risk of electric shock.





## Discharging instructions\*

### Introduction to discharging methods

Some models can power household appliances through external equipment. This function is called vehicle-to-load (V2L).

- ◇ V2L: Provides 220V power to household appliances (such as mobile phones, computers, etc.) through the V2L discharger.

### Discharging precautions

Please read and observe the followings carefully before discharging your vehicle.

#### **WARNING**

- ◆ Do not modify or disassemble the discharging device without authorization, otherwise it may cause discharge failure and fire.
- ◆ Do not discharge your vehicle when the discharging device is scratched, rusted, cracked, or the surface of the discharger, discharging cable, discharging power strip, etc. is damaged, etc.
- ◆ Do not use the discharger and the vehicle charging port when they are deformed, blackened or ablated, otherwise the vehicle or discharging device may be damaged, and in severe cases, personal injury may occur.
- ◆ Do not discharge the vehicle in a place with flammable materials, and a ventilated place is recommended.
- ◆ Minors are prohibited from using the discharging device or from approaching the vehicle being discharged.
- ◆ Do not perform discharge operations outdoors on rainy days and thundery days. Rain or humid conditions may cause the discharging device to leak electricity, and lightning may also cause damage to the discharging device.

#### **WARNING (Cont'd)**

- ◆ To avoid personal injury, it is prohibited to touch the discharging cable and discharging power strip when the vehicle is being discharged.
- ◆ During the discharging, users with implanted medical equipment such as pacemakers need to stay away from the vehicle being discharged to avoid electromagnetic interference affecting the operation of the medical equipment.
- ◆ During the discharging, if you find any odor or smoke in the vehicle, please stop discharging the vehicle immediately and contact the GAC AION sales store.
- ◆ After the discharging, do not disconnect the discharging device with wet hands or standing in water, otherwise it may cause electric shock and personal injury.

#### **CAUTION**

- ◆ Do not directly pull the cable to move the discharging device, and please handle it with care.
- ◆ Before the discharging, please check whether the discharger and the vehicle charging port are clean and free of foreign objects. Otherwise the discharging may fail or the vehicle charging port may be damaged.
- ◆ During the discharging, do not use a high-pressure washing device to wash the charging port. Otherwise, it may result in discharging failure, even causing damage to the vehicle or discharging device.
- ◆ Make sure that the discharging device is disconnected and the charging port cover is closed before starting the vehicle.



## **i** NOTE

- ◆ It is recommended to use the discharging function in an environment where the maximum temperature does not exceed 45°C.
- ◆ When using the discharging function in a low-temperature environment, please use it indoors as much as possible to ensure normal discharging. When the temperature is too low, the discharging function may not work properly.
- ◆ Try to use the discharging function when the traction battery SOC is relatively high, otherwise it may be restricted.
- ◆ When the traction battery SOC is low, the discharging function may not be enabled.
- ◆ When the traction battery SOC is low, the discharging function may automatically stop.
- ◆ It is recommended to use the discharging function when the vehicle traction battery has sufficient power.
- ◆ The vehicle must be in parked state before it can be discharged.
- ◆ When the discharging device is not in use, the vehicle-side discharger should be unplugged in time to avoid increasing power consumption.
- ◆ The maximum discharging power is 3.3kW and the discharging voltage is 220V.
- ◆ The discharge limit can be set through the center console display (discharging will stop when it reaches this value).

## Discharging\*

### V2L discharger

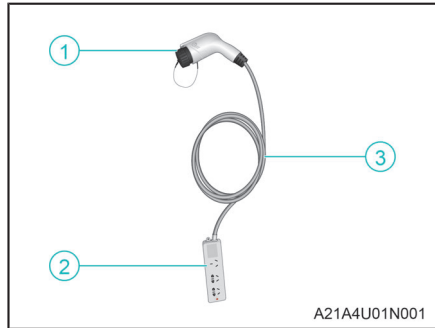

- ① Discharger
- ② Discharging power strip
- ③ Discharging cable

### V2L method

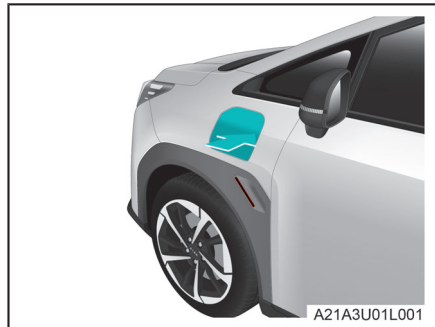

1. Unlock the vehicle, press the rear edge of the AC charging port cover located on the left side of the vehicle to open it.

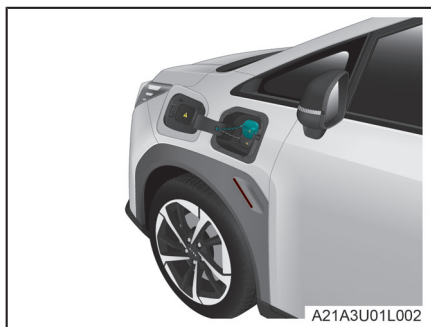

2. Open the AC charging port dust cap.

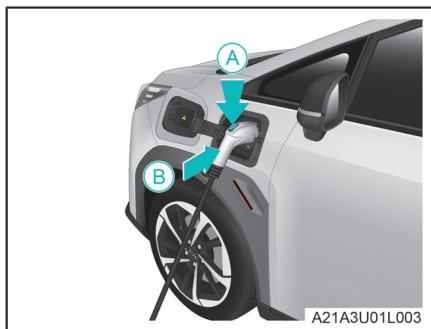

3. While pressing the unlocking button of the discharger in the direction of arrow A, insert the discharger in the direction of arrow B.

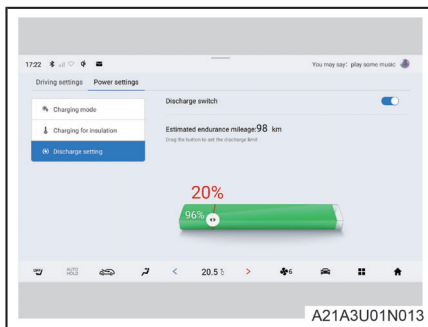

4. Turn on the discharging function on the driving and energy consumption interface of the center console display (the red indicator lamp on the discharging power strip comes on), and connect the electrical consumer.
5. After using the discharging function, unplug the electrical consumer from the power strip, turn off the discharging function on the driving and energy consumption interface (the red indicator lamp on the discharging power strip goes out).
6. After discharging, press and hold the discharger unlocking button on the smart key to unlock the discharger.

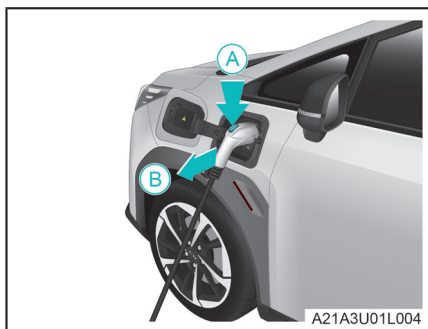

7. While pressing the discharger unlocking button in the direction of arrow A, unplug the discharger in the direction of arrow B.
8. Close the charging port dust cap and the charging port cover, and put the discharger back to its original place.

### **WARNING**

- ◆ When discharging, you must first plug the discharger into the charging port of the vehicle, and then press the discharging switch.

### **NOTE**

- ◆ During discharging, the electronic lock will lock the discharger to prevent it from being stolen or the discharging function being accidentally interrupted.
- ◆ During discharging, after unlocking the discharger, if it is not pulled out for a long time, the electronic lock will re-lock it.
- ◆ After the discharging ends, if you need to re-enter this function, please pull out the discharger and plug it in again, and then press the discharging switch.
- ◆ The above-mentioned V2L discharger is a discharger specially supplied by GAC AION. If required, you can contact the GAC AION sales store for consultation and purchase.
- ◆ It is recommended to use a discharger specially supplied by GAC AION to avoid affecting the discharging function.



## Emergency unlocking/locking

The emergency unlocking/locking features of this vehicle include emergency extension of hidden door handle, emergency unlocking/locking by mechanical key, emergency locking of passenger's door, automatic unlocking program in case of collision, emergency unlocking device of liftgate, and emergency unlocking device of charger.

### Emergency extension of hidden door handle

When the hidden door handle is frozen by rain or snow or stuck by foreign objects and cannot extend out after the vehicle is unlocked, emergency extension of the hidden door handle can be achieved by the following methods:

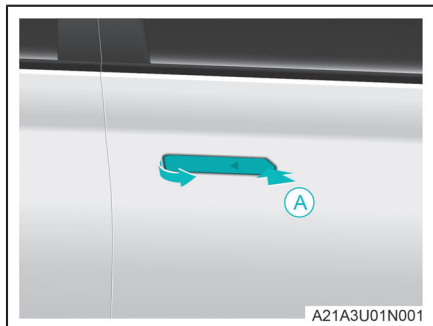

1. Press the front side of the door handle in the direction of arrow A to uplift the rear side.
2. Pull the handle to open the door.

### NOTE

- ◆ All four hidden door handles support emergency extension. The above content is introduced with the right front door as an example.

### Emergency unlocking/locking by mechanical key

The mechanical key is inside the smart key. When the door cannot be unlocked/locked by the smart key, the mechanical key can be used to perform the operation. The specific steps are as follows:

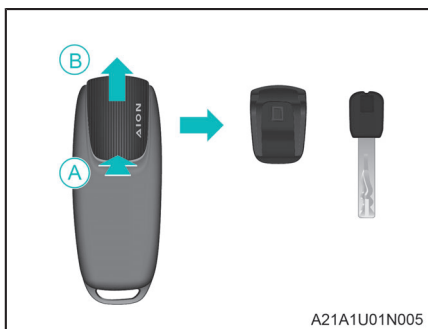

1. Press the mechanical key in the direction of arrow A shown in the figure, and push out the mechanical key cover in the direction of arrow B to take out the mechanical key.
2. Pop out the hidden door handle.

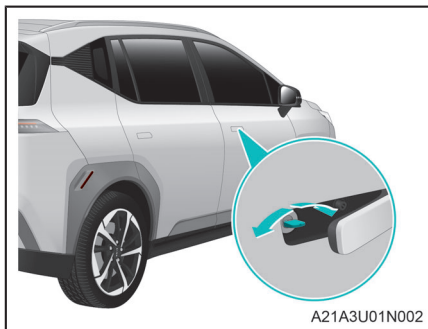

3. Insert the mechanical key into the keyhole, and turn the mechanical key to unlock or lock the door.



## Emergency locking of passenger's door

1. Open the passenger's door to be locked.

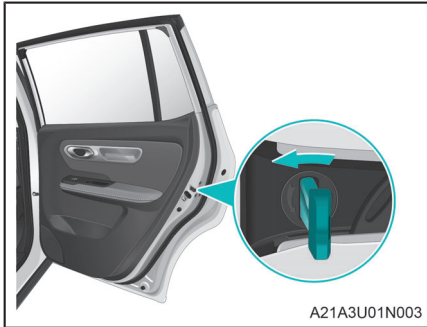

2. Insert the mechanical key into the keyhole in the door lock, turn the key clockwise to the locked position, pull out the mechanical key, and close the door to lock the door.

### NOTE

- ◆ All passenger's doors support emergency locking.
- ◆ After the vehicle is locked with the smart key, the anti-theft alarm will be triggered if you use the mechanical key to unlock the door. In this case, enter the vehicle, place the smart key at the mark, depress the brake pedal and power on the vehicle to release the anti-theft alarm.

## Collision-sensitive unlocking

When a collision is detected, all doors will be unlocked automatically and the locking function of the vehicle will be disabled temporarily.

## Emergency unlocking of liftgate

When you cannot open the doors and liftgate normally inside the vehicle in an emergency, the liftgate can be unlocked with the emergency unlocking device of liftgate. The specific steps are as follows:

1. Enter the trunk.

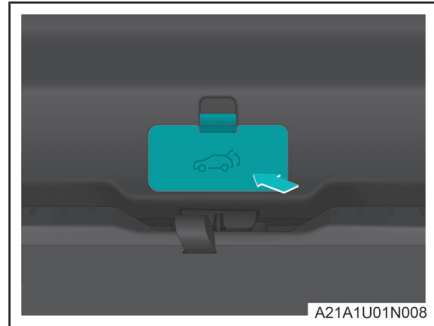

2. Remove the liftgate emergency unlocking port cover from the liftgate guard plate.

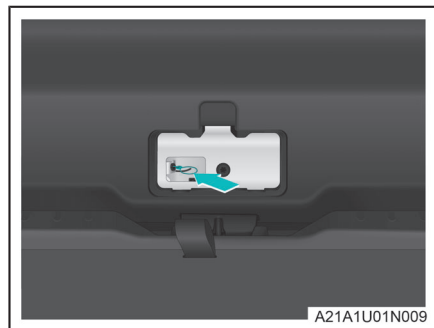

3. Pull the liftgate manual unlocking cable to unlock the liftgate.

## Emergency unlocking of charger

If the charger cannot be unlocked by the charger unlocking button on the smart key, it can be unlocked by the emergency unlocking device of charger. The specific steps are as follows:

1. Open the hood and support it firmly with the stay bar.

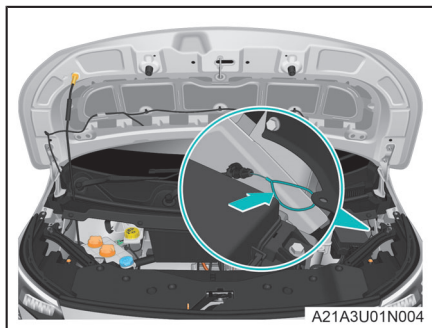

2. Pull the charger manual unlocking cable to unlock the charger.

## Window initialization

If the one-button raising and lowering function and anti-pinch function of power window fail, or the anti-pinch function fails because it is triggered multiple times in a short period of time, the power window needs to be initialized again.

### Window initialization operation

After starting the vehicle, pull the window button (of the window needing initialization) until the window is completely closed, and then hold the button pulled for 2~3s to complete the initialization.

### WARNING

- ◆ The anti-pinch function of the sunroof is disabled during the initialization and learning; therefore, please do not use any part of your body or other objects to hinder the closing of the window; otherwise, it may lead to initialization failure or window damage, or even personal injuries.

### NOTE

- ◆ If the button is released during the window movement, reinitialize the window.
- ◆ If the one-button raising and lowering function and anti-pinch function of power window are still not recovered after the initialization, contact the GAC AION sales store for repair.



## Sunroof initialization

In some cases (such as sudden battery loss, long-term stop or repeated malposition of sunroof/sunshade), the sunroof/sunshade may need manual initialization and self-learning.

### Sunroof initialization operation

After starting the vehicle, keep the sunroof closed, press and hold the CLOSE button to make the sunroof move to the fully open position, and then continue the closing operation, and after the sunroof is completely closed, release the CLOSE button to complete initialization and self-learning.

### Sunshade initialization operation

After starting the vehicle, keep the sunshade open, press and hold the sunshade close button to move the sunshade to the fully closed position until a touch is heard, indicating that the initialization and self-learning are completed.

#### WARNING

- ◆ The anti-pinch function of the sunroof is disabled during the initialization and learning; therefore in this process, do not try to hinder the closing of sunroof by stretching any body part or placing any obstacles, otherwise, damage may be caused and the initialization result may be affected.

#### NOTE

- ◆ If the button is released during the sunroof/shade movement, reinitialize the sunroof/shade.
- ◆ If the automatic opening/closing function and anti-pinch function of the sunroof/sunshade are still not recovered after the initialization, contact the GAC AION sales store for repair.

## Turning on hazard warning lamps



If the vehicle is faulty or involved in a traffic accident, please turn on the hazard warning lamps to alert other vehicles.

The hazard warning lamps can be turned on or off by pressing the switch.

#### CAUTION

- ◆ When the vehicle is powered off, do not turn on the hazard warning lamps unless necessary, so as to prevent the battery from running out of power.

#### NOTE

- ◆ If the hazard warning lamps cannot work properly, other methods that comply with the relevant traffic rules and regulations must be taken to draw the attention of other drivers to your vehicle.





## Wearing reflective vest



The vehicle is equipped with a reflective vest, which you can put in the cabin for use when needed.

### WARNING

- ◆ If you need to get out of your vehicle to check or handle vehicle faults during driving, regardless of the lighting conditions, be sure to wear a reflective vest to attract the attention of passersby or other drivers.

### NOTE

- ◆ If the reflective vest is seriously damaged or dirty, it will affect the reflection effect. It is recommended to replace the reflective vest with a new one in time.

## Setting up warning triangle

### Location of warning triangle

The vehicle is equipped with a warning triangle, which is placed under the trunk carpet and can be used after taking it out and unfolding it.

### Placement distance of warning triangle

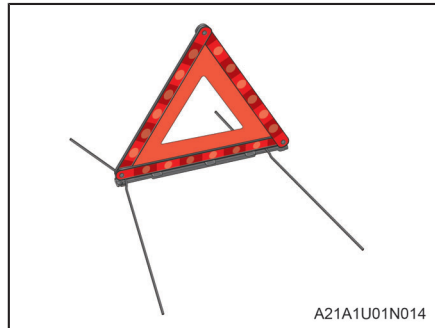

Item	Ordinary road	Highway
Placement distance L	Day: L≥50m Night: L≥80m Special circumstances (rain or bend, etc.): L≥150m	L≥150m

### NOTE

- ◆ The value provided here is for reference only.
- ◆ Please use the warning triangle correctly according to the corresponding national laws and regulations.



## Emergency toolkit

The driver's tools are located under the trunk carpet.

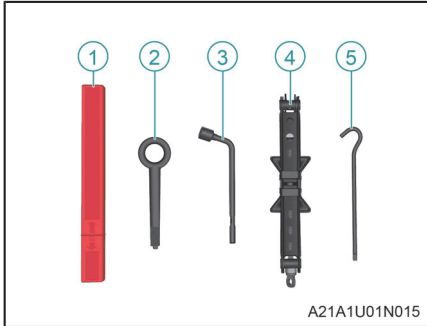

- ① Warning triangle
- ② Towing hook
- ③ Wheel bolt wrench
- ④ Jack
- ⑤ Special wrench for jack

### NOTE

- ◆ In order to deal with various emergencies, you shall be familiar with the locations and usage of tools such as towing hooks.
- ◆ The used tools shall be cleaned in time and placed back to their original positions.
- ◆ Depending on model configurations, the driver's tools may vary. Please refer to the actual vehicle.

## Tire replacement

### Inspecting the wear pattern of tire



There is a raised "tread wear indicator" ① on the front of the tire. If the tread pattern wears to the indicator surface, the tire can no longer be used safely and must be replaced immediately.

The position of the tread wear indicator is indicated by the pattern ② on the sidewall of each tire.

### Tire rotation

Regular tire rotation is recommended to avoid uneven tire wear and extend the service life of tires.

After tire rotation, adjust the tire pressure to the standard value.

## Tire burst

If a tire burst occurs during driving, operate as follows:

1. Hold the steering wheel with both hands, and do not allow it to rotate freely.
2. Decelerate slowly by depressing the brake pedal gently at the same time.
3. Ensure that the vehicle runs straight ahead in the original direction.
4. After the vehicle speed drops, drive the vehicle slowly to park it in a safe area.
5. Replace the tire or make a rescue call as needed.



### WARNING

- ◆ Do not depress the brake pedal sharply; otherwise, the vehicle may lose balance and thus turn over.
- ◆ Turn on the hazard warning lamp timely, and place a warning triangle behind the vehicle as specified to avoid secondary accidents.

## Spare tire

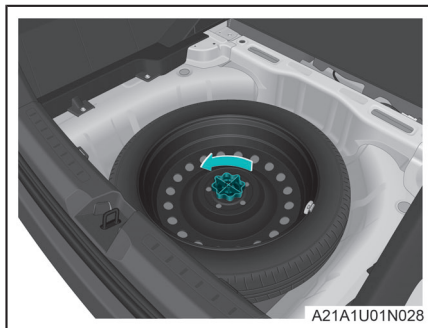

The spare tire is located in the trunk. The spare tire shall not be removed before the trunk carpet and driver's tools are removed.

Unscrew the spare tire fixing handwheel in the direction of the arrow shown in the figure, and take out the spare tire.



### CAUTION

- ◆ Check the pressure of the spare tire regularly to ensure that it is at the standard value.
- ◆ Check the spare tire regularly, and do not use a damaged spare tire.
- ◆ Check whether the tire pressure is at the standard value after the spare tire is installed.
- ◆ Do not place the oil and spare tire together to avoid corrosion of the spare tire due to oil leakage, which will reduce the service life of the spare tire.
- ◆ It is recommended to replace a spare tire that has been used for more than 4 years.



**i NOTE**

- ◆ Spare tires can only be used temporarily for emergency. In this case, the maximum driving speed shall not exceed 80km/h, the traveled distance shall not exceed 50km, and sharp acceleration and emergency braking shall be avoided.
- ◆ The vehicle is equipped with non-full-size spare tires.

### Replacing tires

Preparations:

- ◇ Park the vehicle in a hard, flat and safe place.
- ◇ Shift to “P” gear to enable the parking brake.
- ◇ Turn on the hazard warning lamp.
- ◇ Make sure that all occupants get off the vehicle and wait in a safe place.
- ◇ Turn off the vehicle power switch.
- ◇ Place a warning triangle behind the vehicle as specified according to the actual situation.
- ◇ Place a stopper in front of tire in the diagonal direction of the flat tire to prevent the vehicle from sliding.
- ◇ Take out the driver’s tools such as the jack and wheel bolt wrench.
- ◇ Take out the spare tire.

Remove a damaged tire in the following steps:

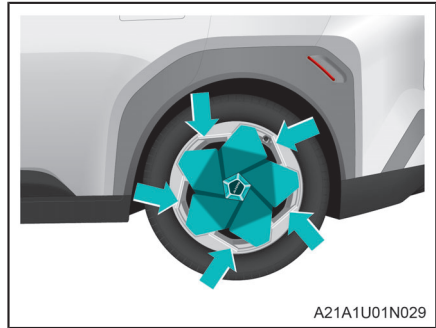

1. Remove the hubcap. (if available)

**i NOTE**

- ◆ No tools are needed. Just apply force to the positions as indicated by the arrows in the illustration to remove the hubcap.

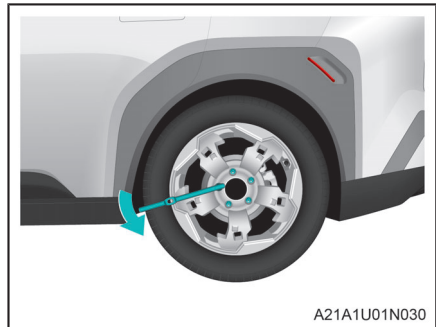

2. Turn the wheel bolts counterclockwise with the wheel bolt wrench, to loosen them by 1~2 turns.



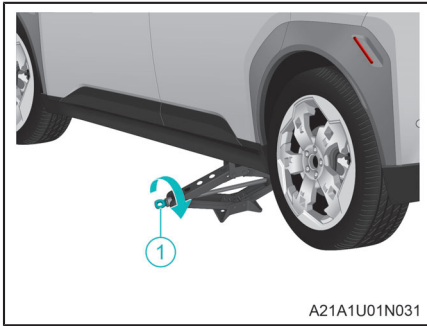

3. Turn the jack ① clockwise so that the jack is close to the lifting point of the body.

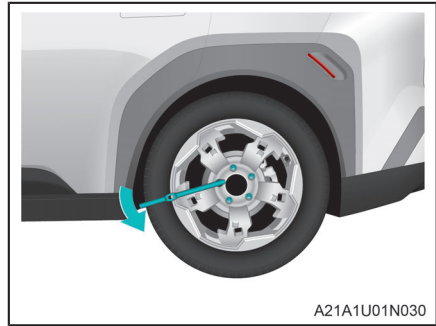

5. Remove the wheel bolts, and take off the damaged wheel.

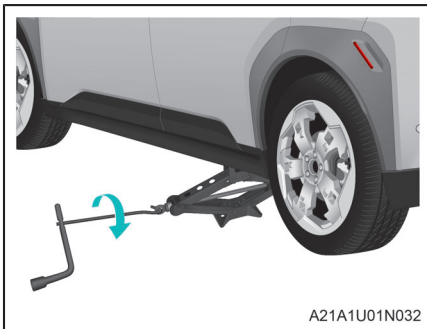

4. Insert the special wrench for jack into the jack, turn the special wrench for jack clockwise with the wheel bolt wrench, and slowly raise the jack to lift the tire off the ground slightly.

Install the spare tire in the following steps:

1. Before installing the spare tire, wipe off all corrosives from the mounting surface with a shop towel.
2. Place the spare tire vertically in the installation position, align the bolts with the bolt mounting holes, and try to tighten the wheel bolts by hand, and then, slightly pre-tighten the wheel bolt with the wheel bolt wrench.
3. Lower the vehicle.

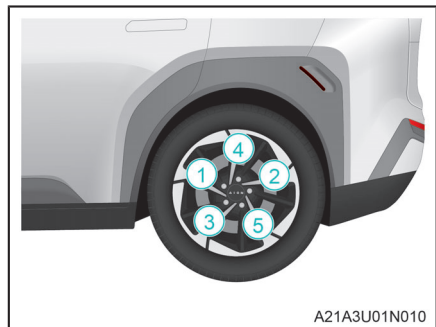

4. Tighten the wheel bolts to the specified torque in the order shown in the figure.
5. Take out the jack, place the replaced tire and all the driver's tools back to the trunk and fix them.



After tire replacement, check the followings;

- ◇ Check the tire pressure after the replacement, and adjust the tire pressure to the standard value. If the tire pressure is lower than the standard value, drive the vehicle slowly to the nearest GAC AION sales store for inflation.
- ◇ Make sure that all the driver's tools have been properly placed.

## WARNING

- ◆ The areas around the hub and brake will be very hot after driving. In this case, do not touch the area around the hub or brake immediately; otherwise, it may cause a scald.
- ◆ Do not install wheel trims that have been severely damaged; otherwise, they may detach from the wheel during driving, causing a traffic accident.
- ◆ Do not use cracked or deformed wheel bolts; otherwise, the wheel bolts may get loose or the wheel may detach, causing a traffic accident.
- ◆ Before lowering the vehicle after tire replacement, make sure that no part of the body of all personnel will be injured as the vehicle is lowered to the ground.

## NOTE

- ◆ For vehicles equipped with a TPMS, it is recommended to contact the GAC AION sales store for tire rotation or replacement.  
The tire and rim used in the illustration above are for reference only. Please refer to the actual vehicle.

## Jump start

If the low voltage battery has been depleted, you can try to start your vehicle via jumper cables and a low voltage battery of another vehicle.

### Connecting jumper cable

Connect the jumper cable in the following steps:

1. Connect one end of the red positive (+) cable to the positive (+) terminal of the dead battery of the vehicle being rescued.
2. Connect the other end of the red positive (+) cable to the positive (+) terminal of the live battery of the rescue vehicle.
3. Connect one end of the black negative (-) cable to the negative (-) terminal of the live battery of the rescue vehicle.

## CAUTION

- ◆ Do not let the cable clamp on the other end of the black negative (-) cable come into contact with anything before performing Step 4.

4. Connect the other end of the black negative (-) cable to a suitable grounding point (clean and unpainted solid grounded metal component) of the vehicle being rescued.

## CAUTION

- ◆ Keep away from the negative (-) battery terminal.
- ◆ Do not connect the other end of the black negative (-) cable to a dead battery.

5. Start the rescue vehicle for a period of time, then try to start the vehicle being rescued and hold it for a period of time to charge the vehicle fully.



## NOTE

- ◆ If the vehicle being rescued cannot be started after several attempts, it is recommended to contact the GAC AION sales store for treatment.

### Disconnecting jumper cable

Disconnect the jumper cable in the following steps:

1. Disconnect the black negative (-) cable from the vehicle being rescued (vehicle with dead battery).
2. Disconnect the black negative (-) cable from the rescue vehicle (vehicle with live battery).
3. Disconnect the red positive (+) cable from the rescue vehicle (vehicle with live battery).
4. Disconnect the red positive (+) cable from the vehicle being rescued (vehicle with dead battery).

## WARNING

- ◆ If the jumper cable is connected or disconnected in the wrong order, a short circuit in the electrical load may occur, causing vehicle damage or personal injury. The resulting repair is outside the warranty coverage.
- ◆ Be sure to connect and disconnect the jumper cables in the correct order and make sure that the cables do not come into contact with each other or other metals to prevent accidents.
- ◆ Not batteries of all vehicles can be used. Only batteries with a rated voltage of 12V can be used for jump start.

## Emergency start of vehicle

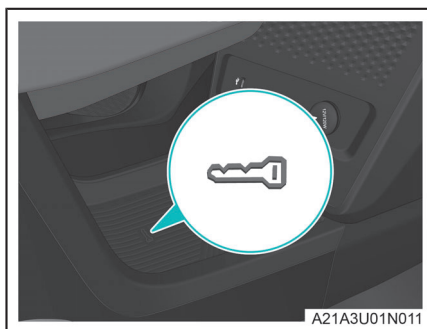

When the battery of smart key runs out or is low, enter the vehicle, place the smart key at the mark, depress the brake pedal and power on the vehicle, and then move the column shifter as soon as possible to start the vehicle.

## NOTE

- ◆ After power-on, move the column shifter as soon as possible to start the vehicle; otherwise, the emergency power-on operation needs to be performed again.



### Emergency power-off of vehicle

When the vehicle is stopped, if power-off cannot be achieved in the vehicle for some special reasons (such as crash/ black screen of center console), the vehicle power supply can be switched off by pressing and holding the “P” position switch for a period of time.

#### NOTE

- ◆ During emergency power-off by pressing and holding the “P” gear switch, relevant prompts will pop up on the instrument. In this case, the vehicle power supply can be switched off by pressing and holding the “P” gear switch for a period of time.





## Freeing stuck vehicle

If the vehicle is stuck on a soft road such as sandy, muddy or snowy road, follow the steps below to get it unstuck:

1. Power off the vehicle, and remove mud, snow or sand around the front wheels.
2. Place wooden blocks, stones or other objects under the front wheels to help increase the adhesion and friction.
3. Start the vehicle and accelerate slowly to get the vehicle out of the trap.

### WARNING

- ◆ If the vehicle is to be driven out of the trap by pushing the vehicle from the front and rear, make sure that the surrounding area is spacious and unimpeded to avoid colliding with other vehicles, objects or people. When the vehicle is driven out of the trap, it may suddenly rush forward or backward, so extra care shall be taken.

### NOTE

- ◆ If the vehicle still cannot get out of the trap after several attempts, it is required to have a tow truck for rescue.

## Vehicle towing

If the vehicle needs to be towed, it shall be towed by the GAC AION sales store or a professional towing company.

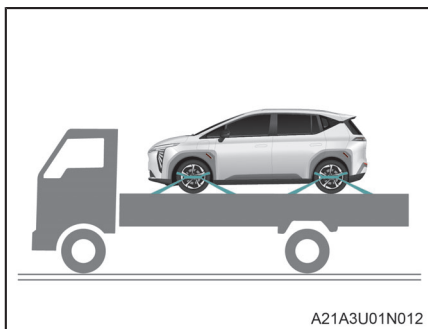

A21A3U01N012

It is recommended to use a flatbed trailer.

### CAUTION

- ◆ Keep the front and rear wheels off the ground during vehicle towing.
- ◆ Towing with a hoist trailer is prohibited; otherwise, the vehicle may be damaged.

### NOTE

- ◆ For towing, be sure to use the safety chain system and comply with the relevant national/provincial (municipal) and local laws and regulations.



### Installing a towing hook

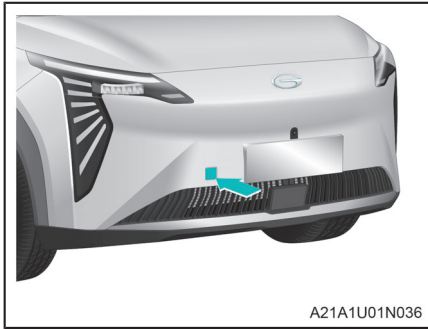

1. Open the towing eye cover at the lower right of the front bumper.

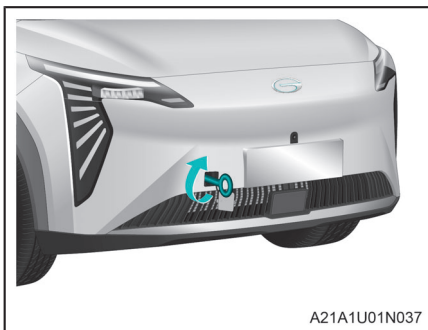

2. Insert the towing hook into the towing port, turn it clockwise and tighten it.

### WARNING

- ◆ When installing a towing hook, make sure to tighten it. If the towing hook is loose, it may fall off during towing, causing serious personal injuries or vehicle damage.
- ◆ If the vehicle is stuck in mud or sand, or if it is required to pull the vehicle out with a towing hook due to other circumstances, make sure to observe the precautions related to getting the vehicle out of a trap; otherwise, the towing rope or chain may break due to the excessive tension applied, thus causing serious personal injuries or vehicle damage.
- ◆ During vehicle towing, the driver must sit in the vehicle to control the steering wheel and brake pedal to avoid personal injuries and vehicle damage during towing.



**i CAUTION**

- ◆ Before towing, check whether the towing hook is broken or damaged.
- ◆ Straight-line towing shall be kept as much as possible. Do not tow the vehicle from one side or at a vertical angle to avoid damaging the towing hook and the vehicle.
- ◆ Do not yank the towing hook. The force application shall be smooth and balanced.
- ◆ Do not fix the towing rope or chain to a suspension component.
- ◆ If the vehicle is difficult to move, do not continue the towing, and contact the GAC AION sales store for towing.
- ◆ Towing with a towing hook is only used to help get the vehicle out of the poor road. Driving by towing is prohibited; otherwise, it may cause damage to the vehicle.



## Rescue in case of driving through deep water

If water may enter the vehicle during driving through deep water, follow the steps below:

1. Drive the vehicle away from the water-logged road section, park it in a safe place, and check whether there is water inside the vehicle. If so, clear it.
2. If the vehicle cannot be driven away from the water-logged road section, switch off the vehicle power supply immediately.
3. Disconnect the negative battery terminal if conditions permit.
4. Call the GAC AION's customer service hotline for rescue.
5. If the vehicle is flooded severely, all occupants should be evacuated to a safe place immediately.

### WARNING

- ◆ If the vehicle is soaked in water or falls into water accidentally for weather or special reasons, it is forbidden to power on the vehicle; otherwise, it may cause accidents or secondary damage to the vehicle.

## Rescue in case of battery leakage

### WARNING

- ◆ If a vehicle collision causes the traction battery fluid leakage, a professional rescuer shall wear a protective mask and solvent isolation gloves, and shall not touch the fluid directly.
- ◆ If the leaked fluid is touched accidentally, try to remove the contaminated clothes and immediately rinse the related part with soap and plenty of water for 15min until no chemicals remain. In case of an uncomfortable symptom, seek medical attention immediately.



## Rescue in case of vehicle fire

After the vehicle catches fire, immediately leave the vehicle and evacuate to a safe place, and call the police and rescue phone number.

After the vehicle fire is extinguished, it is recommended to contact the GAC AION sales store for treatment; in this case, do not touch the vehicle subjected to the fire accident to avoid accidents such as electric shock and burns.

### DANGER

- ◆ When the instrument displays a message “Safe parking, emergency leaving” and sends a buzzer sound, it means that the internal temperature of the battery rises sharply and an accident of thermal runaway (overheating, fire, explosion) will occur. In this case, immediately park the vehicle safely and stay away from the vehicle.

**In order to prevent vehicle fires timely and effectively, pay attention to the followings during use:**

- ◇ Never store flammables or explosives in the vehicle.
  - In hot summer days, if flammables or explosives such as lighters, cleaning agents and perfumes are stored in the vehicle, fire and even explosion is likely to occur.
- ◇ Never modify the electrical circuits or install additional electrical components.
  - Installation of additional electrical consumers (such as high-power audio device) will cause excessive load on the electrical line, causing overheating and even fire of harnesses.

- ◇ Go to the GAC AION sales store for inspection and maintenance regularly.

- Check for oil leakage regularly, and remove grease and oil stains from the motor timely to avoid fires caused by volatilization of the grease and oil stains under high temperature conditions.
- Regularly check all electric lines of the vehicle, and check whether the electrical devices and harness connectors are insulated and fixed normally.

- ◇ It is recommended to equip the vehicle with a fire extinguisher and know its operation method.

- An onboard fire extinguisher is recommended to be prepared on the vehicle to ensure the driving safety. Check and replace the fire extinguisher regularly and be familiar with its operation method.

- ◇ Precautions for driving.

- During parking, especially in summer, ensure that there are no flammables (such as hay, dry branches, leaves and wheat stalks) under the vehicle; otherwise, fire may be caused.
- During driving, try to avoid road sections with flammable materials such as dry leaves, wheat straw, and weeds, or stop to check whether there are any of such flammable materials attached to the bottom of the vehicle after driving through such road sections. Try to park the vehicle in a place without sun exposure.



## Vehicle identification number (VIN)

### Location of vehicle identification number (VIN)

The VIN is the ID code of a vehicle and has uniqueness.

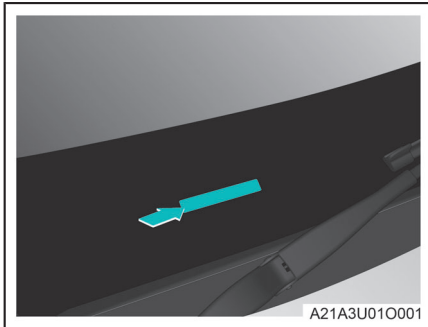

- ◇ The VIN is pasted at the reserved groove on the lower right of the front windshield.

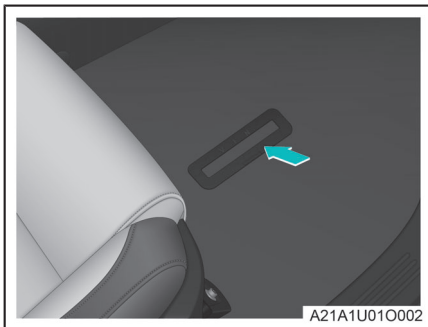

- ◇ The VIN is engraved at the floor in front of the driver's seat.

#### NOTE

- ◆ The location and quantity of the VIN are not complete. Please refer to the actual vehicle.

### Composition of the VIN

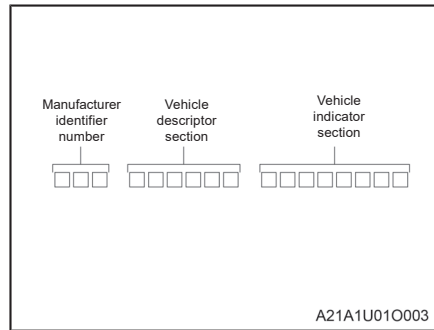

The VIN is composed of 17 characters and contains information such as the country of manufacture, manufacturer, year and vehicle characteristic code.

### Reading VIN with a diagnostic scan tool

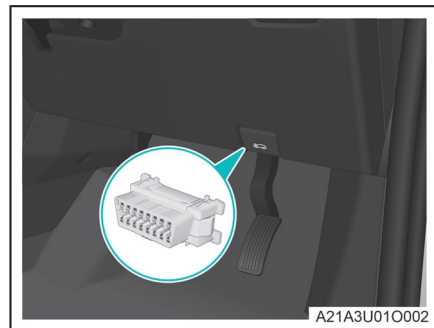

The OBD DLC is located at the lower right rear of the instrument panel. Data such as the VIN and vehicle status information can be read by connecting a special diagnostic scan tool to the OBD DLC.

#### NOTE

- ◆ If you need to diagnose whether the vehicle data is normal, contact the GAC AION sales store for data diagnosis.



## Vehicle nameplate and sticker

### Manufacturer's nameplate

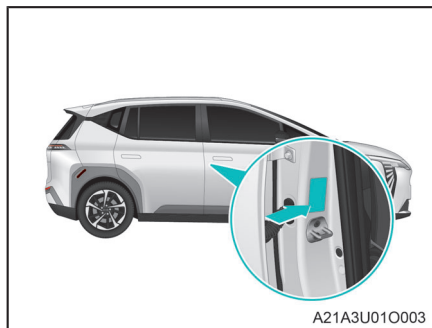

A21A3U01O003

The manufacturer's nameplate is pasted on the near the front door lock catch of B-pillar on the driver side.

The manufacturer's nameplate is marked with the country of manufacture, date of manufacture, VIN, drive motor parameters, traction battery parameters and other information.

### Motor model and number

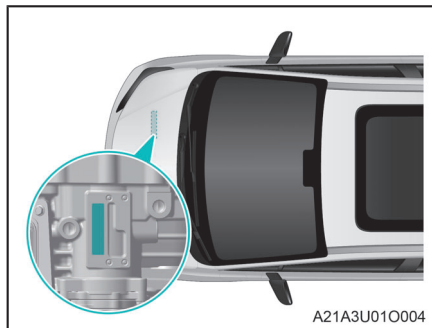

A21A3U01O004

The motor model and number are engraved on the motor housing.

### Vehicle sticker

Vehicle stickers include the child safety lock sticker, airbag warning sign, cooling fan warning sticker, high-voltage component warning sticker, etc. Be sure to read and follow the instructions on the stickers.

#### ◇ Airbag warning sign

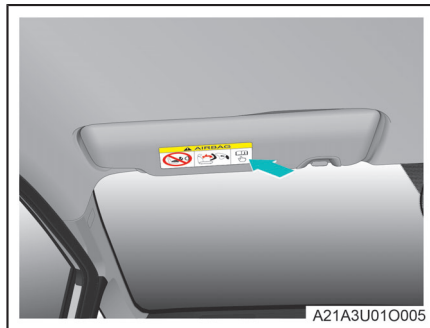

A21A3U01O005

- The airbag warning signs are located on the front and back of sun visor on the front passenger's side.

#### ◇ Cooling fan, coolant warning sticker

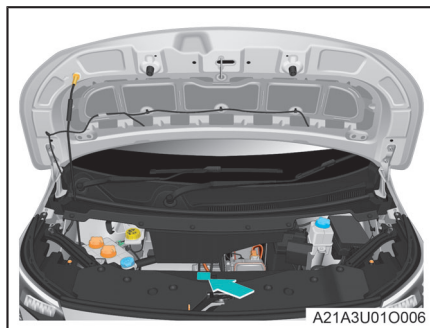

A21A3U01O006

- The cooling fan, coolant warning sticker is located on the motor compartment guard plate.



◇ High-voltage component warning sticker

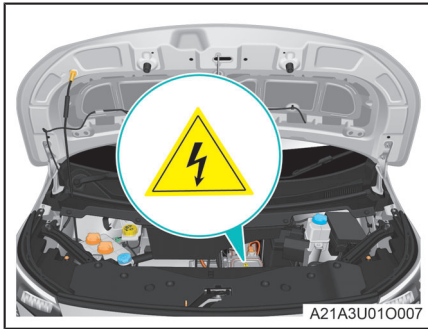

- The warning sticker for high-voltage components such as MCU is located on the housing of concerning high- voltage component.

◇ Charging warning sticker

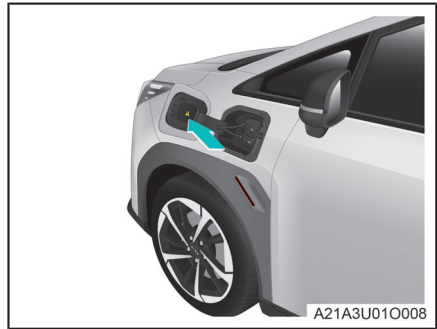

- The charging warning sticker is located on the charging port cover.

◇ Automotive energy consumption sign



- The automotive energy consumption sign is located on the front windshield.
- The automotive energy consumption sign contains information such as the manufacturer, vehicle model, energy type, vehicle mass and electric energy consumption.

**i NOTE**

- ◆ To prevent the sign from affecting the field of vision, remove the sign after purchasing the vehicle.





## Technical parameters of vehicle

Item		Parameter	
Overall dimensions (mm)	Length	4,535	
	Width	1,870	
	Height	1,650	
Wheel track (mm)	Front	1,600	
	Rear	1,600	
Wheelbase (mm)		2,750	
Front/rear overhang (mm)		898/887	
Kerb mass (kg)		1,695/1,750	1,615/1,670
Axle load (kerb mass) (kg)	Front	959/970	902/935
	Rear	736/780	713/735
Gross vehicle weight rating (kg)		2,180	
Axle load (gross vehicle weight rating) (kg)	Front	1,095	
	Rear	1,085	
Min. ground clearance under full load (mm)		150	
Minimum turning diameter (m)		11	
Maximum speed for 1km (km/h)		150	
Range in combined driving cycle (km)		490	410
Power consumption in combined driving cycle (kWh/100km)		13.9	14.5
Maximum gradeability (%)		30	
Approach angle (°)		≥18	
Departure angle (°)		≥27	
Seating capacity		5	



## Technical parameters of motor

Item	Parameter	
Motor model	TZ184XYA2001	TZ184XYA2002
Drive motor type	Permanent magnet synchronous motor	
Drive mode	FF	
Rated power (kW)	38	38
Rated speed (r/min)	4,270	5,400
Rated torque (N•m)	85	85
Peak power (kW)	150	100
Peak speed (r/min)	14,000	14,000
Peak torque (N•m)	225	225



## Technical parameters of traction battery

Item	Parameter	
Type of battery	LFP battery	
Rated voltage (V)	374.4	294.4
Rated capacity (A•h)	169	172.1
Cooling method	Liquid cooling	
Charging temperature (°C)	-20~55	
Storage temperature (°C)	-40~60	
IP rating	IP67	



## Wheel and tire parameters

Item		Parameter
Tire specification		215/55 R17, 215/50 R18, 225/45 R19
Standard tire pressure (kPa)		240~270
Spare tire specifications		T125/80 R17
Standard pressure for spare tire (kPa)		420±10
Four-wheel alignment	Front wheel toe-in	5'±3'
	Front wheel camber	-13'±30'
	Kingpin caster angle of front wheel	7°14'±45'
	Kingpin inclination angle of front wheel	13°23'±45'
	Rear wheel camber	-1°15'±30'
	Rear wheel toe-in	-6'±18'
Dynamic balance of wheels		Single-sided residual unbalance ≤8g
		Total weight of balance weight on both sides ≤120g



## Technical parameters of brake system

Item		Parameter
Type of service brake system		Hydraulic brake, disc brake
Type of parking brake system		EPB
Power mode of brake booster		Vacuum
Free travel of brake pedal (mm)		5.6
Max. travel of brake pedal (mm)		106.4
Reasonable usable range of brake lining pairs	Total thickness of front brake lining (mm)	12
	Allowable wear thickness of front brake lining (mm)	10
	Total thickness of front brake disc (mm)	25
	Allowable wear thickness of front brake disc (mm)	2
	Total thickness of rear brake lining (mm)	10
	Allowable wear thickness of rear brake lining (mm)	8
	Total thickness of rear brake disc (mm)	10
	Allowable wear thickness of rear brake disc (mm)	1



## Type and filled amount of vehicle fluids

Item	Specification	Dosage	Remarks
Brake fluid	DOT4	0.7~0.9L	/
Refrigerant	HFC-134a	530~570g	/
A/C system coolant	G30, -35°C	1.9~2.3L	/
TGW system coolant	G30, -35°C	4.2~5.6L	/
Motor coolant	G30, -35°C	3.6~4.2L	/
Windshield washer fluid	A mixture of 44% methanol with freezing point of -30°C, and 56% water with hardness not more than 205g/t	1.8~2.2L	/
Differential & reducer gear oil	IDEMITSU MOTF TS-1	1.33~1.43L	/



## Index

(Arranged in sequential order of Chinese phonetic alphabets)

### A

AION APP.....	3
Introduction to seat belt .....	18
Seat belt reminder .....	22
Safety grip .....	51
Airbag deployment .....	26
SRS warning lamp.....	25
Introduction to airbag .....	23

### B

Linking the vehicle .....	3
---------------------------	---

### C

Window initialization .....	159
Window control .....	38
Lane Keeping Assist (LKA)* .....	105
Lane Departure Warning (LDW)* .....	102
Long-term storage of vehicle .....	141
Emergency power-off of vehicle .....	168
Window control* .....	5
Vehicle nameplate and sticker .....	175
Rescue in case of vehicle fire .....	173
Vehicle towing .....	169
Rescue in case of driving through deep water .....	172
Vehicle identification number (VIN) ..	174
Freeing stuck vehicle .....	169

Emergency start of vehicle .....	167
Wheel and tire parameters .....	180
Internal maintenance .....	136
Opening doors from inside .....	119
Interior lighting .....	16
Unlocking doors from inside .....	119
Locking doors from inside .....	43
Body anti-theft .....	123
External maintenance .....	135
Opening doors from outside .....	15
Discharging* .....	154
Unlocking vehicle from outside .....	10
Locking vehicle from outside .....	121
Charging instructions .....	124
Storage space .....	49
Wearing reflective vest .....	161

### D

12V power outlet .....	52
Follow Me Home .....	118
Reversing Parking Aid (RPA) .....	111
Light control .....	80
Acoustic Vehicle Alerting System (AVAS)..	78
Low voltage battery maintenance .....	149
Rescue in case of battery leakage .....	172
Technical parameters of motor .....	178
Electric Park Brake (EPB) .....	115

Cruise Control System (CCS)\* ..... 90  
 Maintenance of traction battery ..... 150  
 Technical parameters of traction battery ... 179  
 Multimedia control panel ..... 54  
 Precautions for multimedia use ..... 60

**E**

ISOFIX child restraint system ..... 30  
 LATCH child restraint system ..... 30  
 Safety guidelines for child passengers ..... 28  
 Child safety lock ..... 29  
 Applicability of child seats ..... 31

**F**

Steering wheel adjustment ..... 42  
 Steering wheel control ..... 41  
 Corrosion protection measures ..... 140  
 Discharging instructions\* ..... 153

**G**

Closing all windows ..... 117  
 Closing of liftgate ..... 14  
 Closing sunroof ..... 118

**H**

Driving in cold seasons ..... 109  
 Vanity mirror and vanity mirror lamp ..... 52  
 Shifting gears ..... 74

Tire replacement ..... 162

**J**

Basic operations ..... 54  
 Integrated Cruise Assist (ICA)\* ..... 98  
 Switching of driving modes ..... 72  
 Checking and replacing fuse ..... 147  
 Checking coolant ..... 144  
 Checking brake fluid ..... 145  
 AC charging ..... 126

**K**

Switch-on/off of vehicle power supply ..... 34  
 Opening of liftgate ..... 11  
 Turning on hazard warning lamps ..... 160  
 A/C control ..... 45  
 A/C filter ..... 146  
 Jump start ..... 166

**L**

Bluetooth connection ..... 57  
 Safety notes before leaving ..... 120  
 Tire maintenance ..... 136

**N**

Internal cleaning ..... 133  
 Adjustment of interior rearview mirror ..... 37



## Q

Surround View Monitor (SVM) .....	112
Vehicle start.....	72
Opening and closing hood.....	142
Forward Collision Warning (FCW)* .....	87
Locating of vehicle .....	10

## R

Emergency toolkit .....	162
-------------------------	-----

## S

Setting up warning triangle .....	161
Connection with mobile phone* .....	59
Wireless charging of mobile phone* .....	44

## T

Pedals .....	75
Tire Pressure Monitoring System (TPMS). 70	
Sunroof initialization .....	160
Sunroof control .....	39
Adding windshield washer fluid .....	143

## U

USB port.....	53
---------------	----

## W

External cleaning .....	131
Tilting down of exterior rearview mirror when reversing* .....	111

Adjustment of exterior rearview mirror .....	37
Folding of exterior rearview mirror .....	121
Driving in fog .....	107

## X

Information display .....	68
Check before driving .....	7

## Y

Driving in hot seasons .....	108
Warning lamps on instrument .....	65
Instrument view .....	67
Indicator lamps on instrument .....	62
Emergency unlocking/locking.....	157
Voice assistant* .....	58
Wiper control .....	84
Driving in rain .....	107
Remote setting .....	7
Seat belt use during pregnancy .....	21

## Z

Sun visor .....	51
Technical parameters of vehicle .....	177
Type and filled amount of vehicle fluids ..	182
Correct sitting posture .....	19
Correct use of seat belts .....	20
DC charging .....	129
Brake assist control systems.....	76
Technical parameters of brake system....	181

Smart key .....	8
Intelligent High Beam Control (IHBC)* .....	82
Autonomous Emergency Braking (AEB)* ..	88
AUTO HOLD.....	79
Adaptive Cruise Control (ACC)* .....	91
Seat adjustment .....	35
Seat ventilation* .....	48

